



AI - Fluid Engineering and Exploration Laboratory (AI-FEEL)



HEECHANG LIM (임희창), Professor, PhD

Director of the [AI-FEEL\(Fluid Exploration and Eng\) Lab](#)

Professor in Energy Systems Major, PNU

Director of Wind Energy Research Center (WE-TECH)

Chair for the Graduate School of Convergence for Clean Energy Integrated Power Generation (CEIPG)

Chair for Department head of Integrated Energy Power Gen Combustion

< Collaborators in the laboratory >

- **Research professor:** Mustafa Z Yousif, Linqi Yu
- **PhD students:** YoungWoo Lee, Bonhun Gu, Arash Mohammedi, Haifung Zhou, Meng Zhang, Merrera Senbeto Jiren, Tianle Zhang, He Yi, Yuyang Wang, JinFeng Qiu, Ngo Ahn
- **Msc students:** Zazho Zhu, John Zuluaga, Yuxiao Cao, Zeynam Gamze, Thi Phuong Nghi Pham, Chunxao Pan

< Research Areas >

- **AI/DL applications** (인공지능/딥러닝 응용)
- **Turbulent boundary layer flow** (열유체 난류유동)
- **Blade/airfoil aerodynamics** (공력, 풍력, 수력발전)
- **Computational Fluid Dynamics** (CFD, 수치유체역학)
- **Active Flow Control, Plasma Actuator**(능동유동제어, 플라즈마 액츄에이터)

1. AI and Deep learning

Generation of turbulent inflow conditions

$$I_t^{out} = \mathcal{F}_{AE}(I_t^{in}, W_{AE})$$

$$\mathcal{L}_{AE} = L_{pixel} + L_{perceptual} + L_{gradient} + L_{Reynolds\ stress} + L_{spectrum}$$

$$L_{pixel} = \frac{1}{N} \sum_{t=1}^N \|I_t^{out} - I_t^{in}\|_2^2$$

$$L_{perceptual} = \frac{\beta_1}{N} \sum_{t=1}^N \|\mathcal{F}_{VGG}(I_t^{out}) - \mathcal{F}_{VGG}(I_t^{in})\|_2^2$$

$$L_{gradient} = \frac{\beta_2}{N} \sum_{t=1}^N \|\nabla I_t^{out} - \nabla I_t^{in}\|_2^2$$

$$L_{Reynolds\ stress} = \frac{\beta_3}{N} \sum_{t=1}^N \|R(\mathbf{u}_t^{out}) - R(\mathbf{u}_t^{in})\|_2^2$$

$$L_{spectrum} = \frac{\beta_4}{N} \sum_{t=1}^N \|E(k)_t^{out} - E(k)_t^{in}\|_1$$

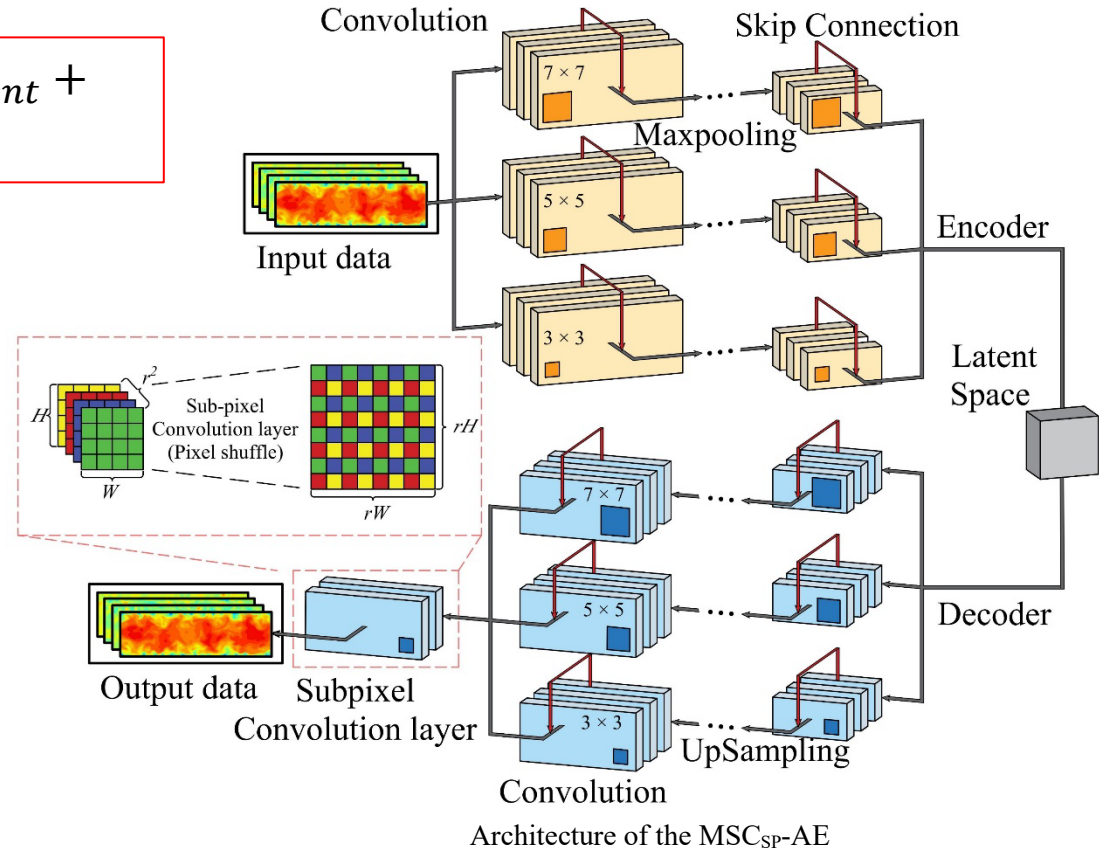

CNN consists of a combination of convolution and pooling or upsampling layers with spatial filters. Each convolution process is followed by a nonlinear activation function.

1. AI and Deep learning

Physics-constrained DRL (PCDRL) for flow field denoising

- This slide proposes a **multi-agent deep reinforcement learning (DRL)-based model for reconstructing flow fields from noisy data**. The physics-constrained DRL (PCDRL) model integrates pixel-wise rewards, physical constraints from the momentum and pressure Poisson equations, and known boundary conditions, enabling training without target data.
- Results demonstrate that **combining DRL models with flow physics can effectively solve complex flow reconstruction problems**, significantly reducing experimental and computational costs.

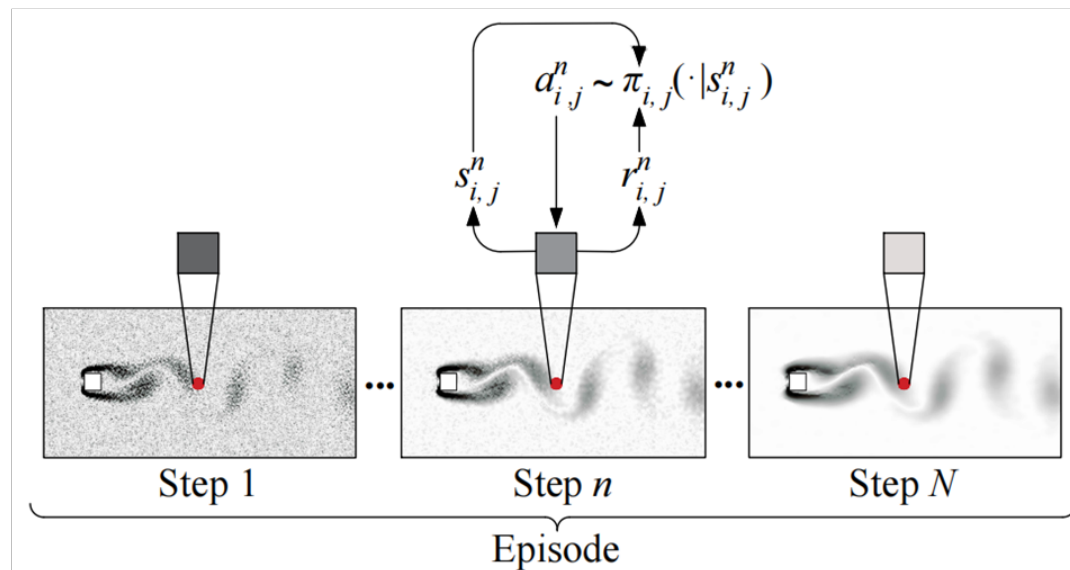

1. AI and Deep learning

Physics-Constrained DRL (PCDRL) for Flow Denoising

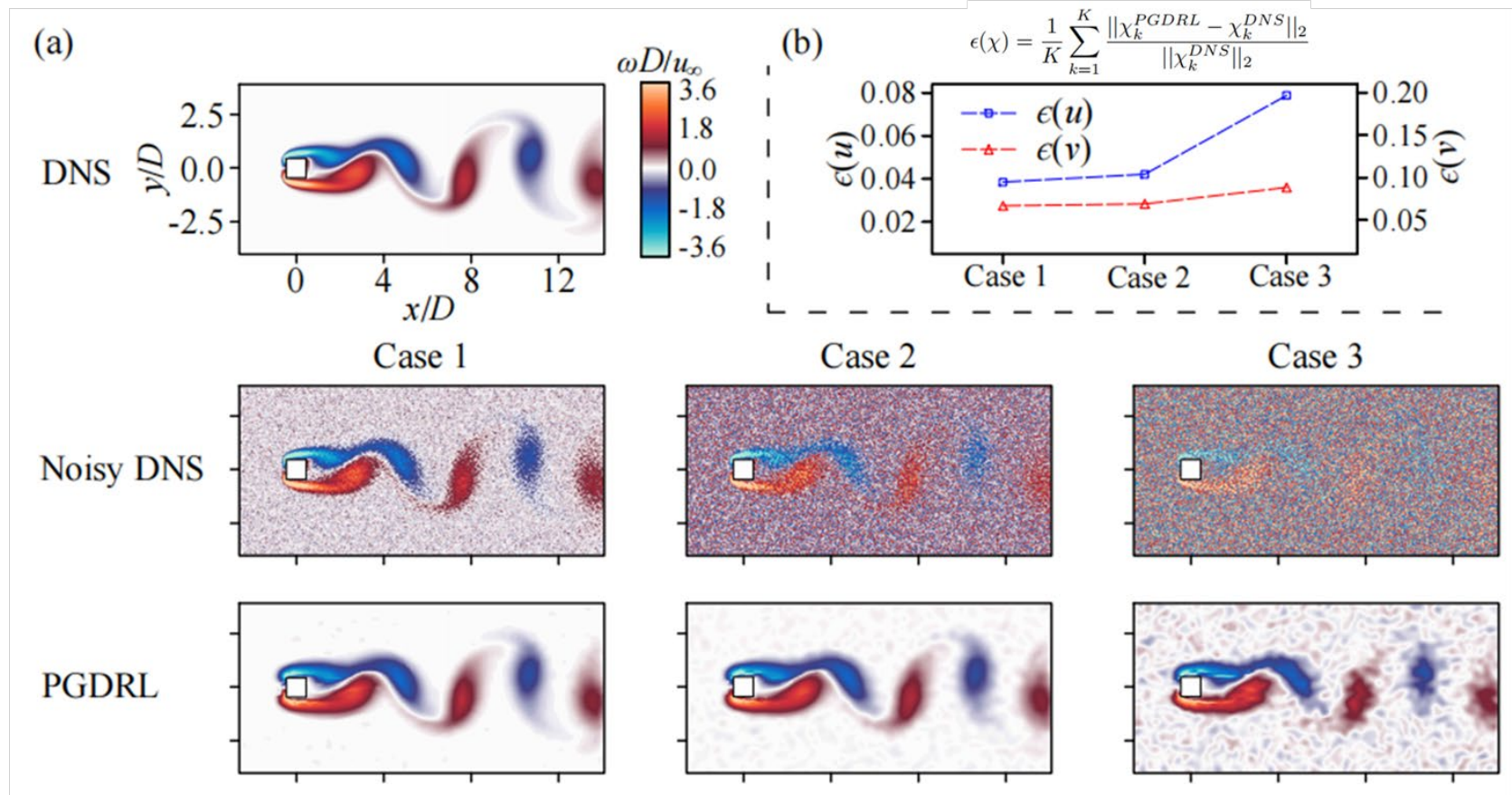

(a) Instantaneous vorticity field; (b) relative L2-norm error of the reconstructed velocity fields. Cases 1, 2 and 3 represent the noisy DNS data at noise levels $1/\text{SNR} = 0.01, 0.1$ and 1 , respectively.

1. AI and Deep learning

Physics-Constrained DRL (PCDRL) for Flow Denoising

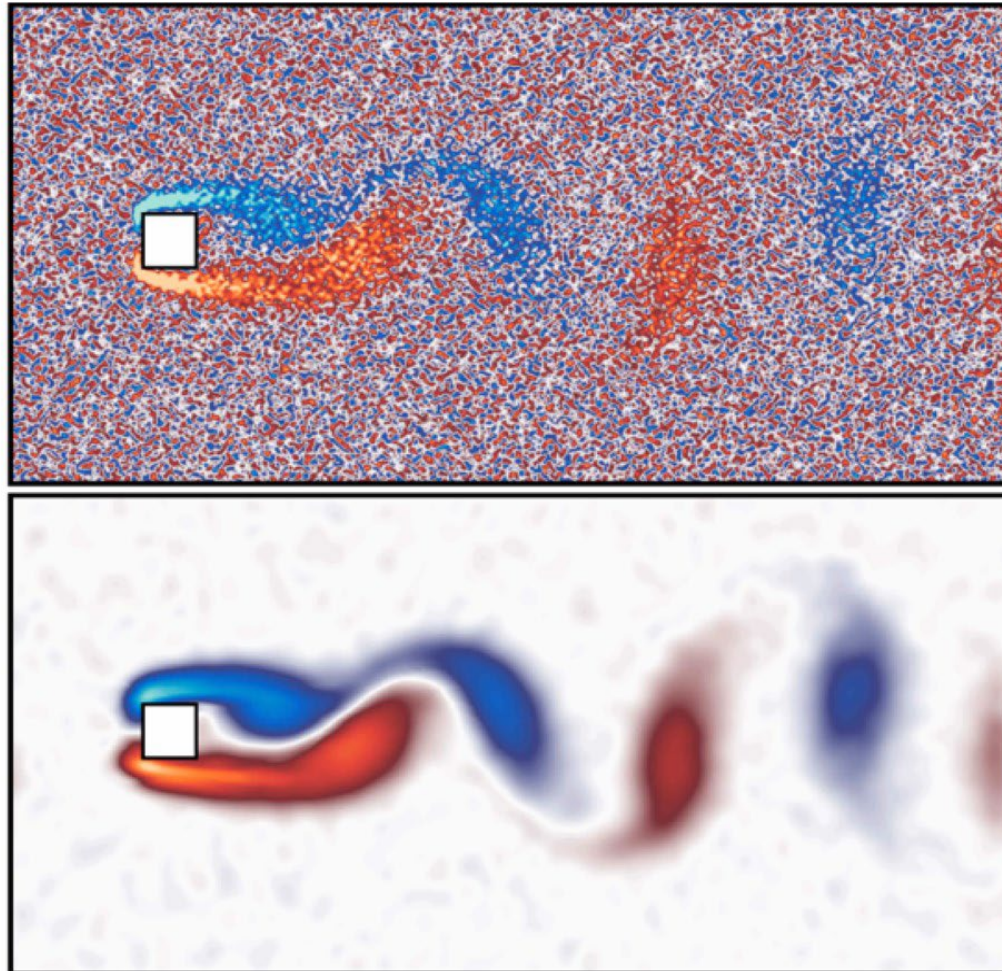

1. AI and Deep learning

Hybrid Control Framework for Wind Turbines Based on PI Control and DRL

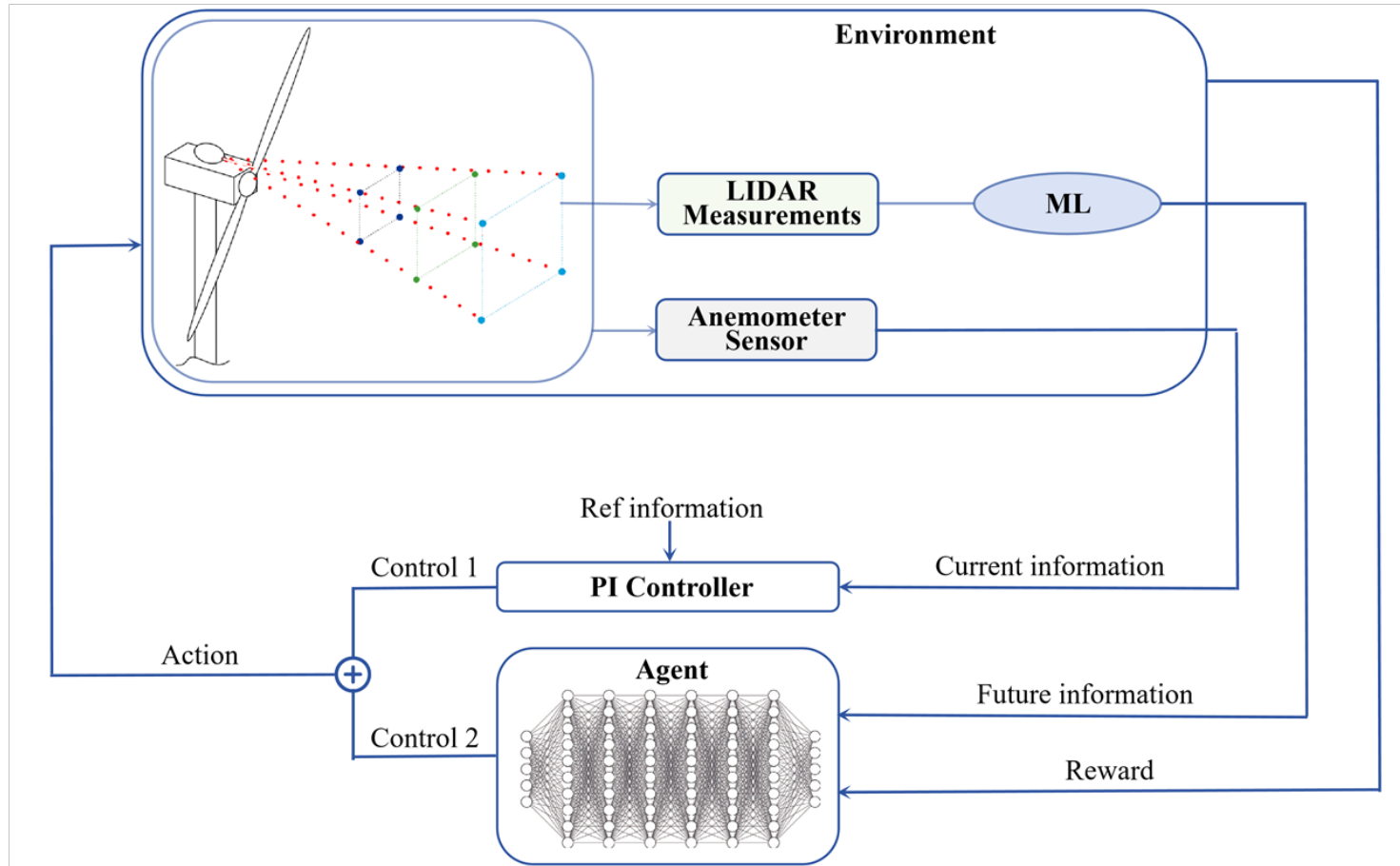

This diagram illustrates a hybrid control framework for wind turbines, combining traditional PI control with a reinforcement learning agent. The system leverages LIDAR and anemometer sensor data processed by a machine learning model to provide both current and predictive wind information, enabling more efficient turbine control decisions.

1. AI and Deep learning

Transformer inflow generator (Dr Yousif) 2-10-1-4

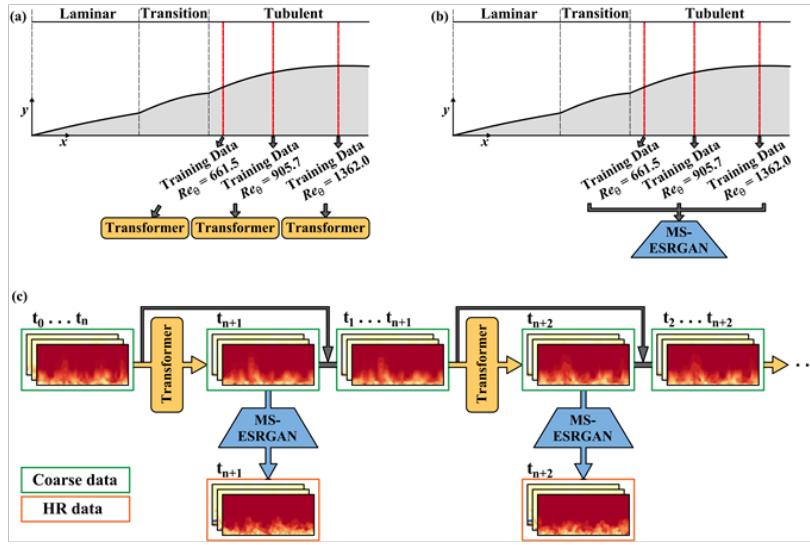

Yousif et al., JFM (2023)

M-GAN based Velocity Estimator (Mr Yu) 1-10-2-5

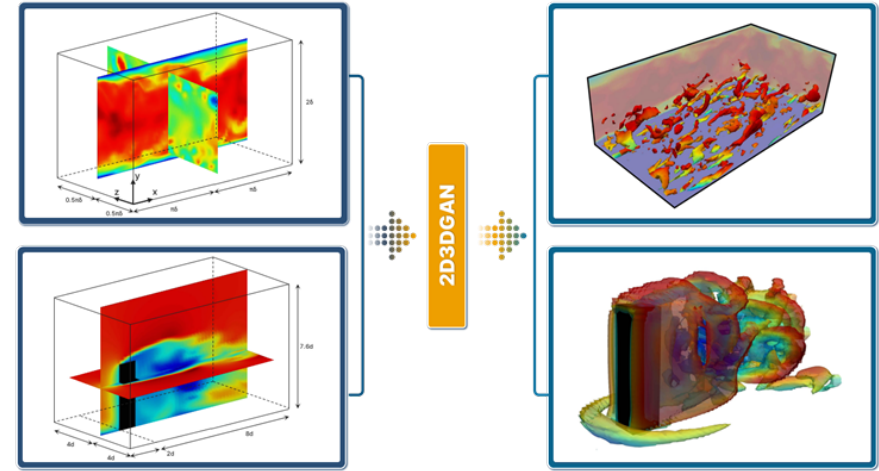

Yu et al., under review PRF (2024)

PGDRL based flow denoising (Ms Zhang) 4-10-2-4

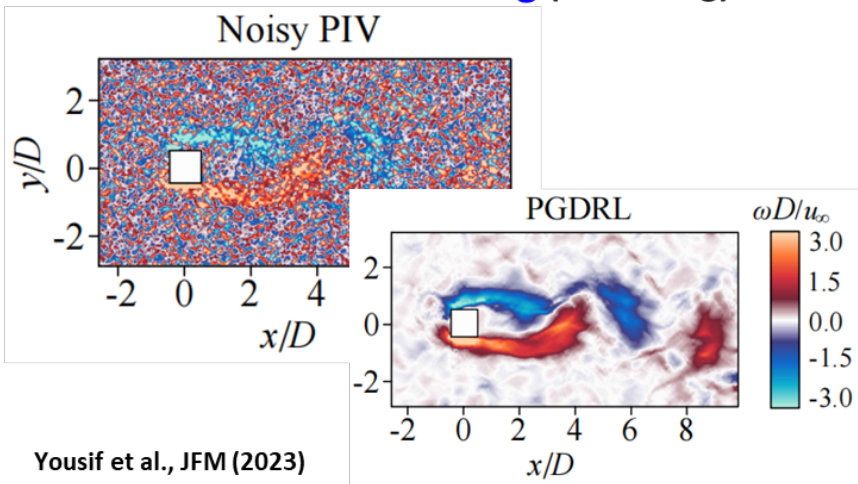

Yousif et al., JFM (2023)

DRL active flow control (Ms Kolesova) 2-10-1-3

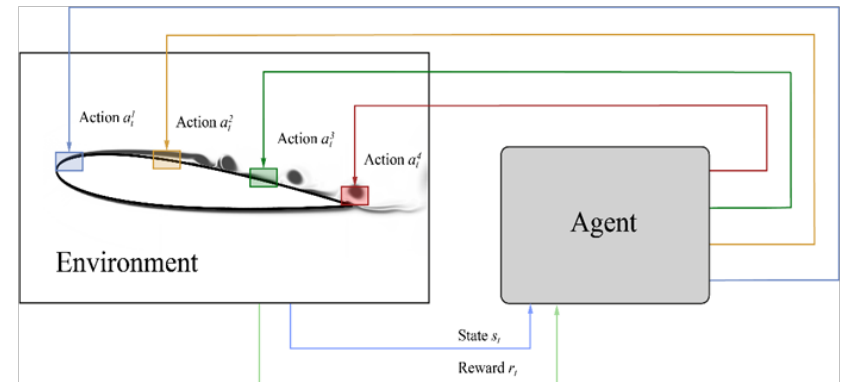

Paraskovia et al., Physics of Fluids (2023)

2. Aerodynamics (블레이드/물체 공력특성)

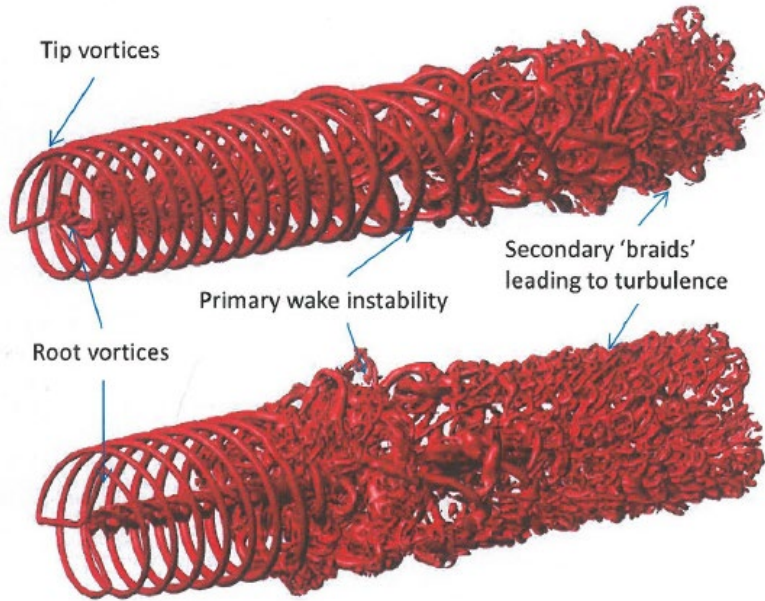

Wake flow behind turbine blades

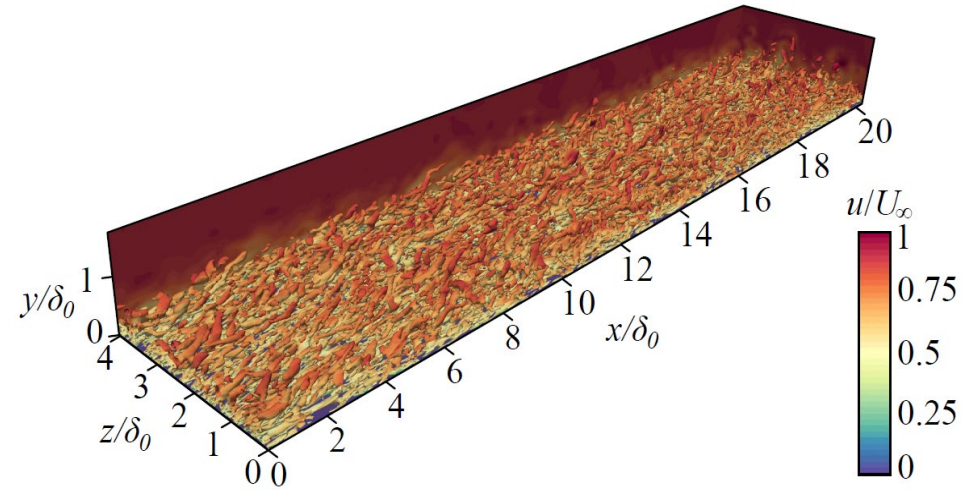

Turbulent Boundary Layer ($Re_\tau = 550$)

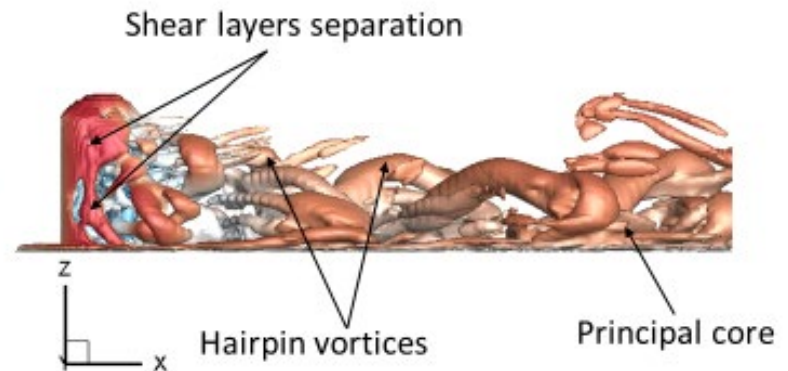
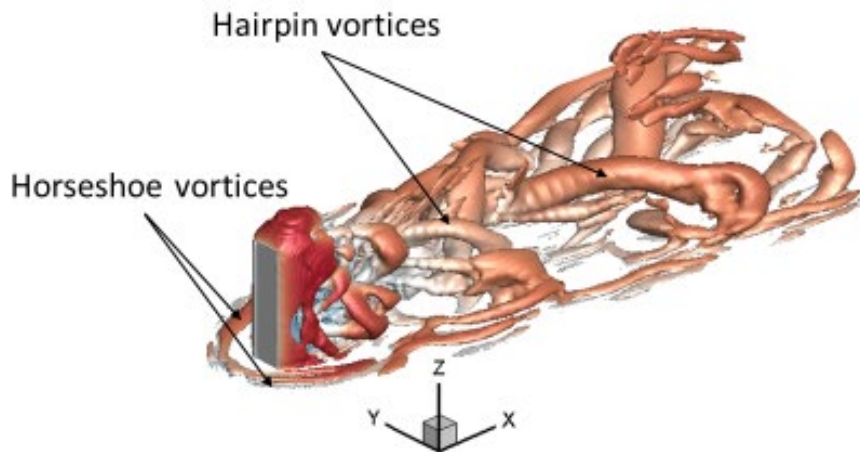

Wake flow behind a finite body

3. Modelling Wind Flow over Bodies

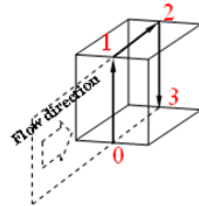
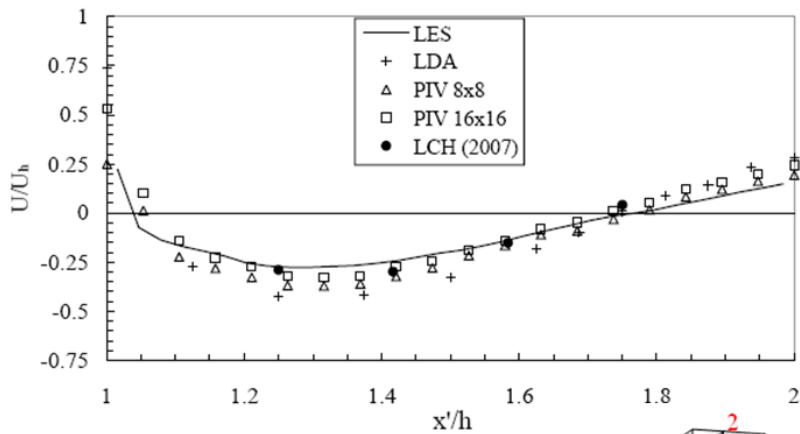

Reynolds number range in this study

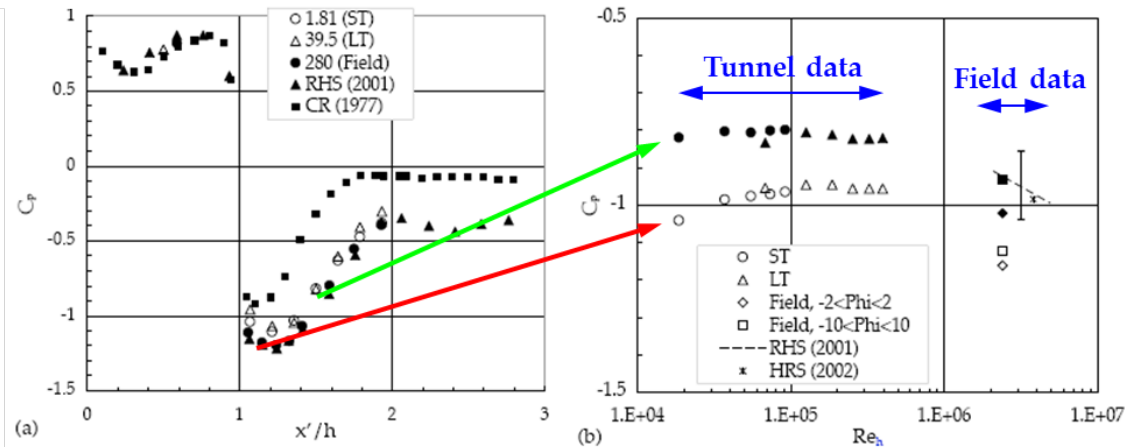
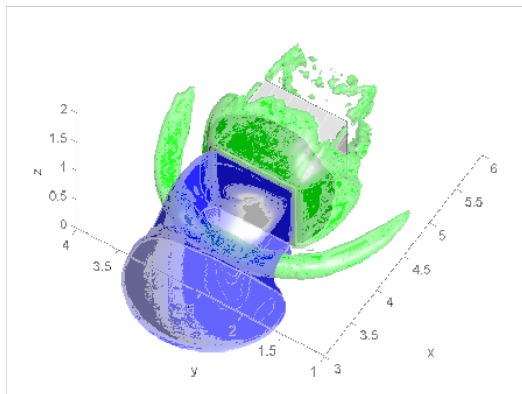
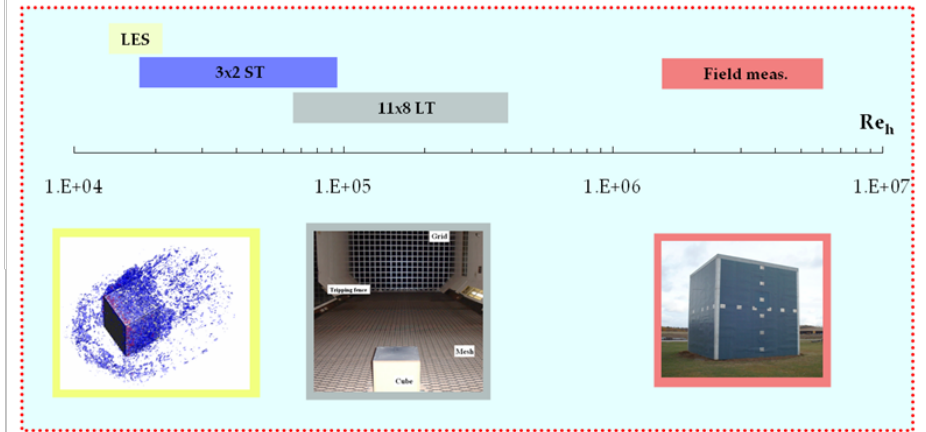
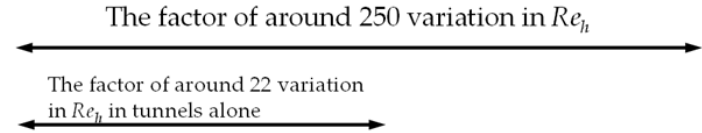

4. Renewable Energy (Wind Turbine)

Boundary condition in CFD

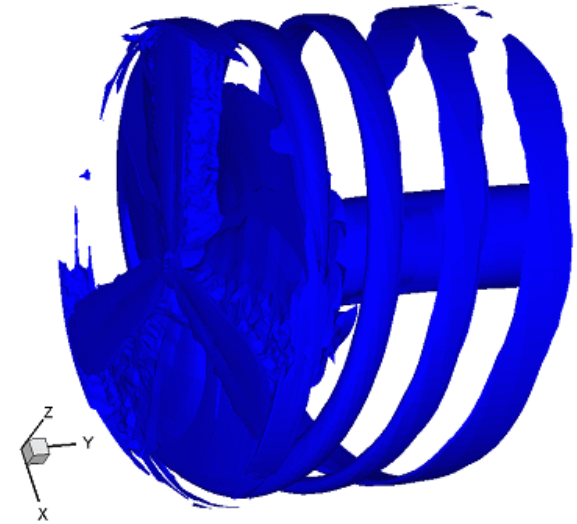
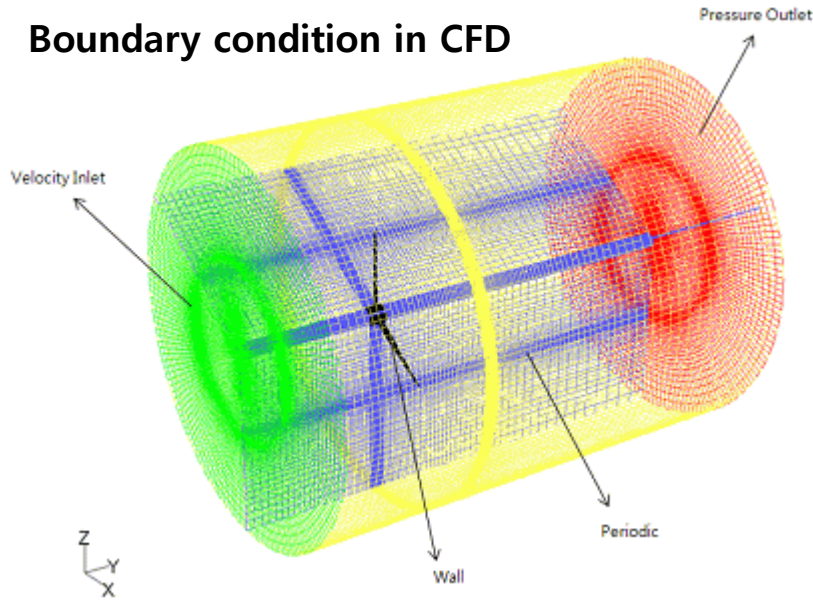

Wake flow behind a wind turbine

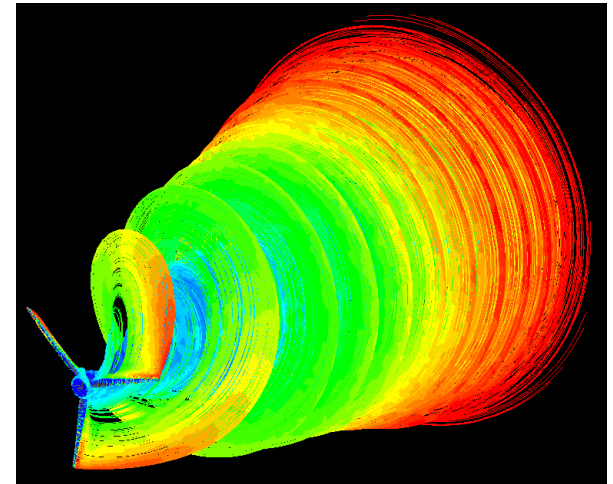
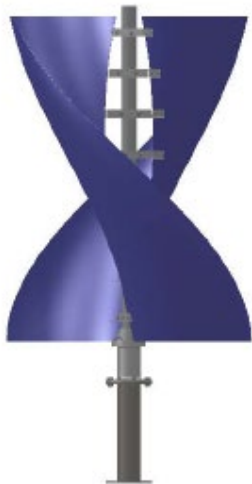

5. PIV Measurement Techniques

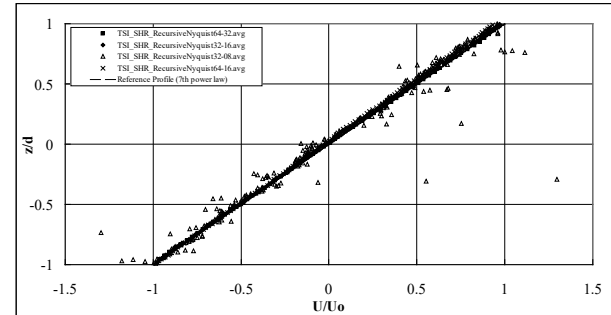
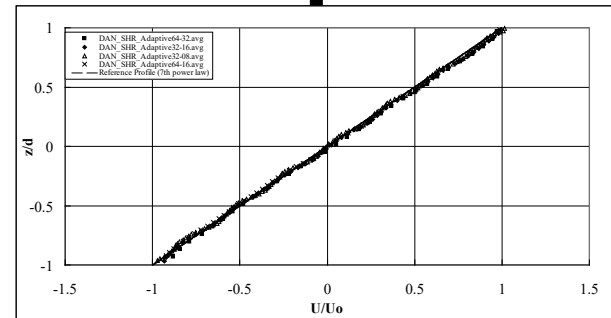
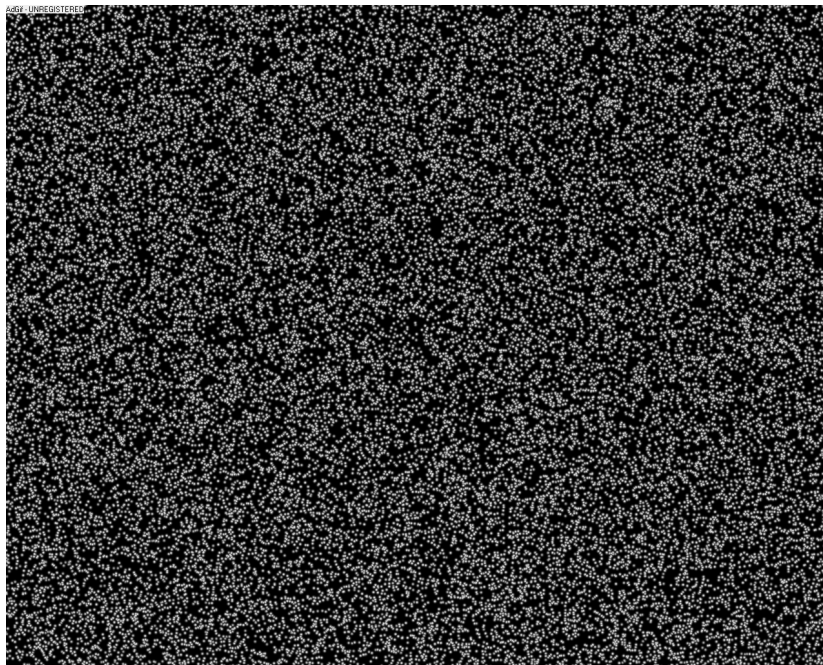

Speed distribution behind a rectangular cylinder without a triggering [U=3m/s]

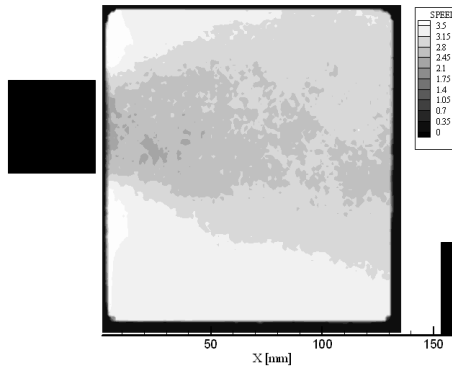

Speed distribution behind a rectangular cylinder with a triggering [U=3m/s]

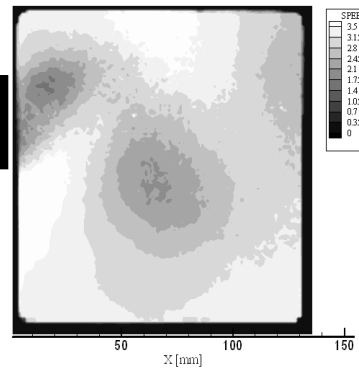

$$R_{u_1 u_2} = \frac{\overline{u_1' u_2'}}{\sqrt{\overline{u_1'^2}} \sqrt{\overline{u_2'^2}}}$$

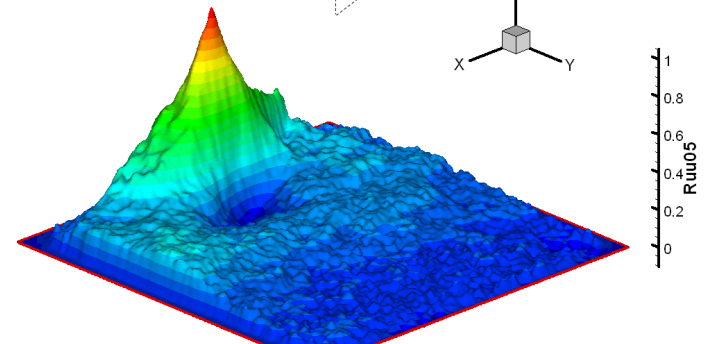
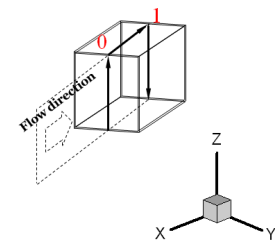

6. CFD Calculation

Cavity with flow oscillations

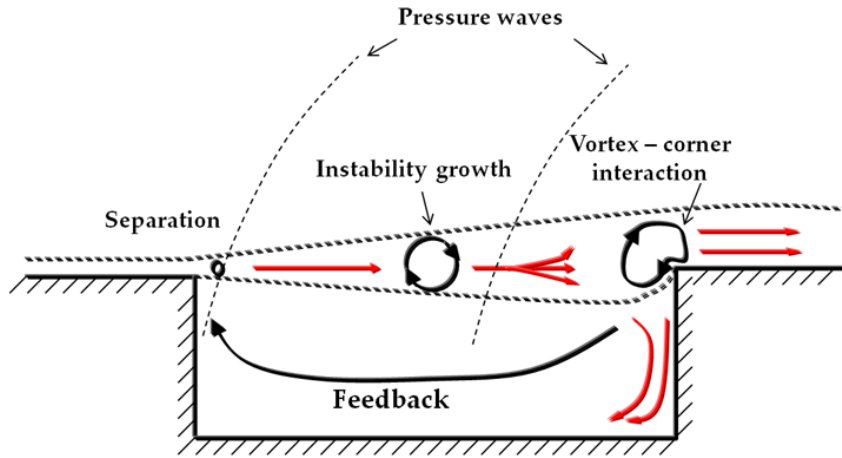

| | Cubical Cavity | Cylindrical Cavity |
|----------------|----------------|--------------------|
| Size | 70 × 70 × 95 | 90 × 90 × 95 |
| Number of Taps | 25 | 27 |

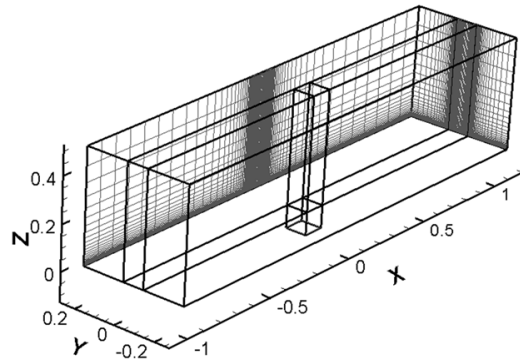
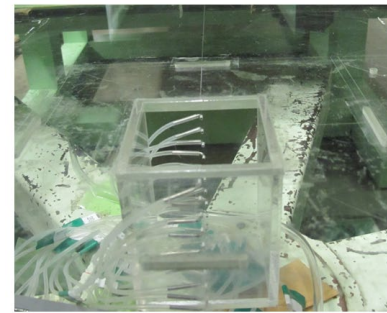

3-different different shape of cavity

- Cubical cavity
- Cylindrical cavity
- Rounded Cylindrical cavity

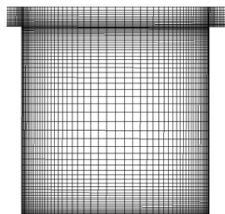

Cubical cavity

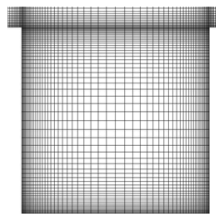

Cylindrical cavity

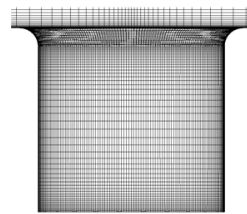

Rounded Cylindrical cavity

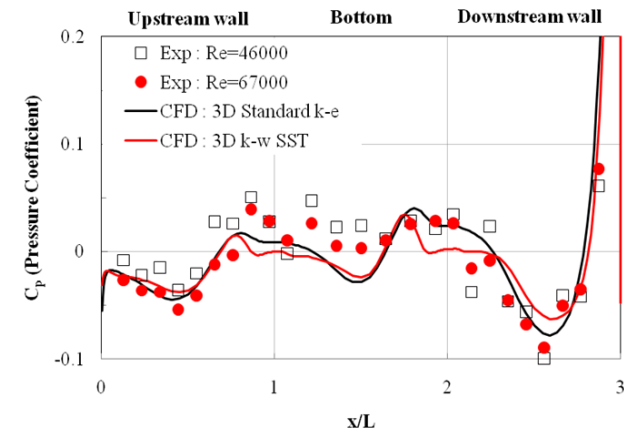
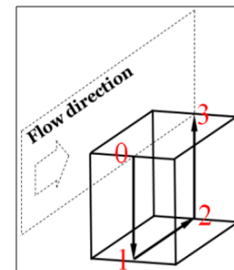

7. Radiated noise prediction by FSI

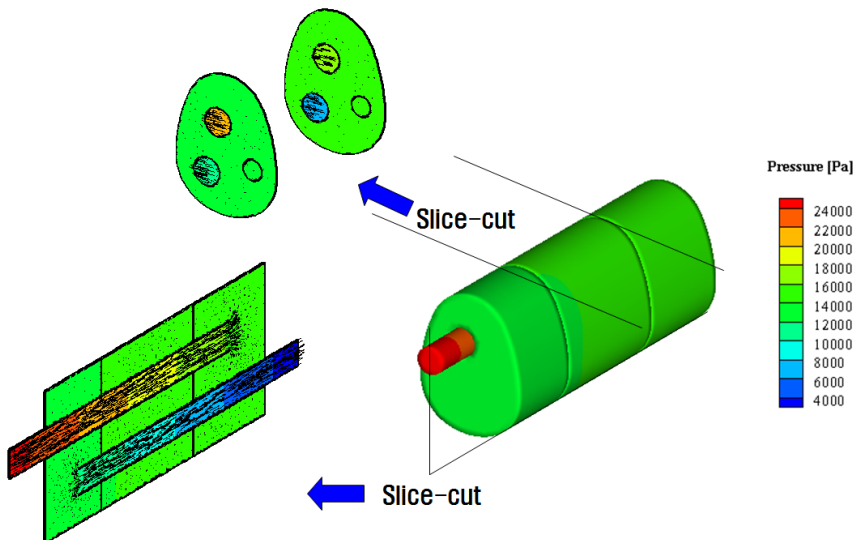
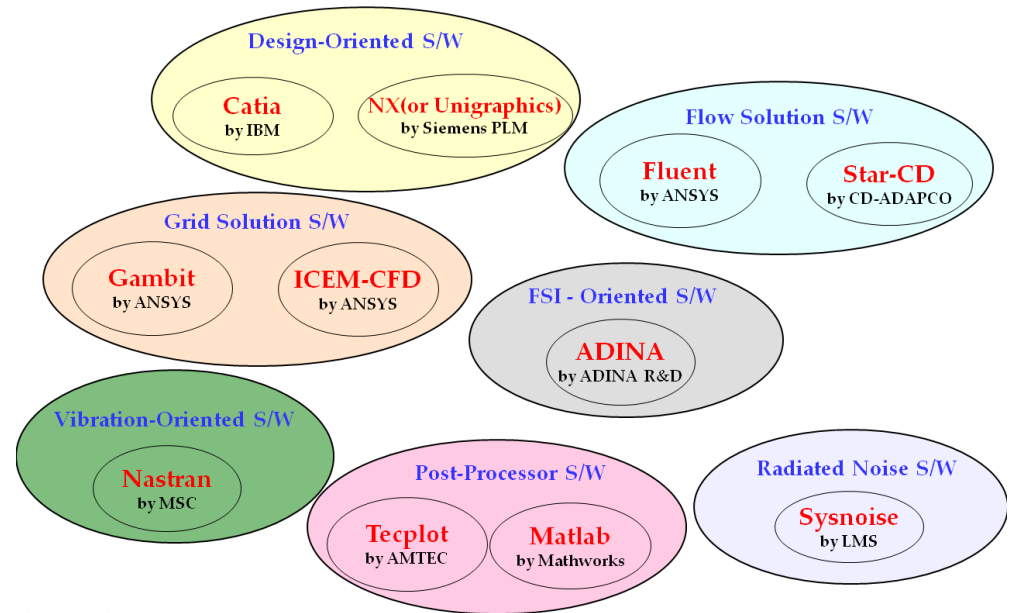
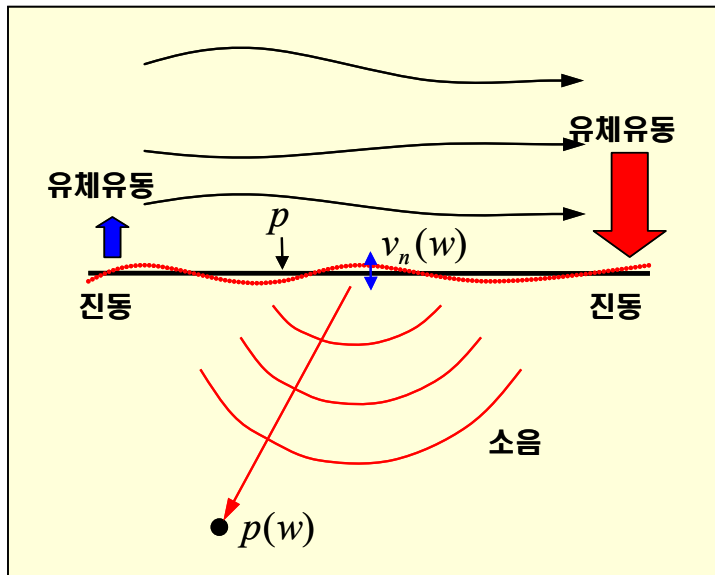

축방향 displacement

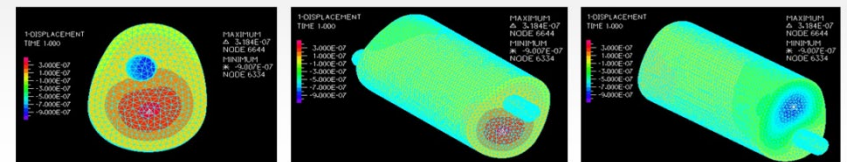

반지름방향 displacement

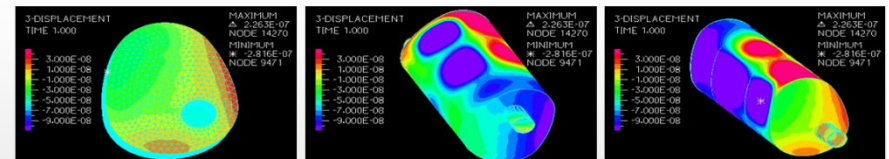

8. High Pressure Vessel Facility

Impact Test Rig 3D Model

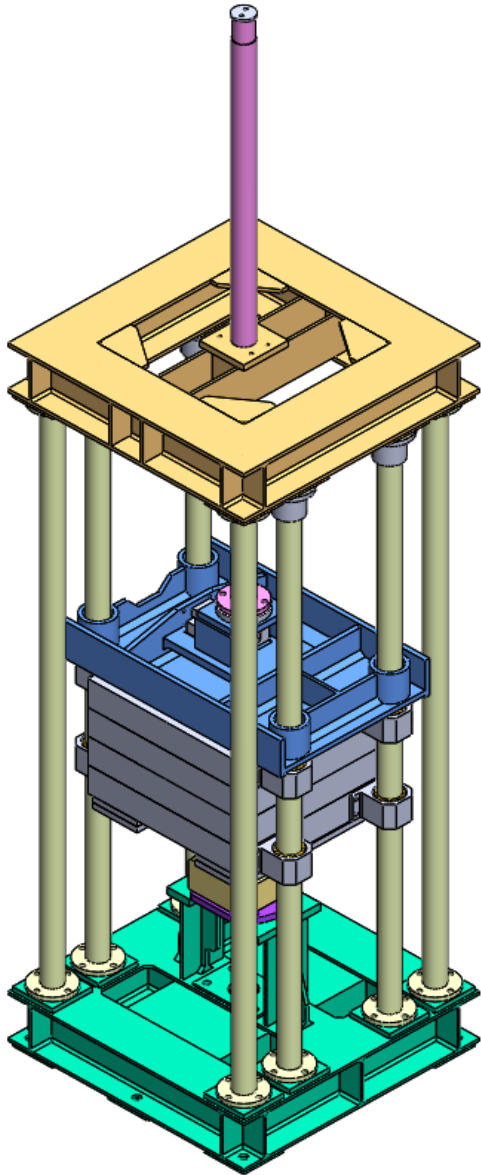

Isometric View

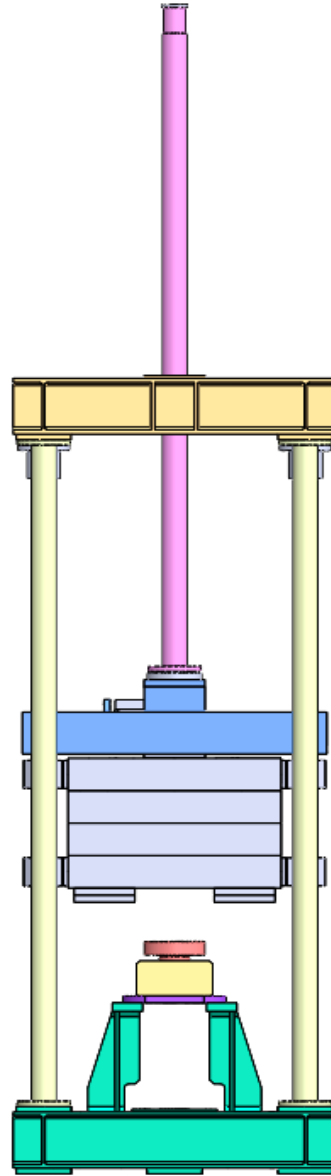

Front View

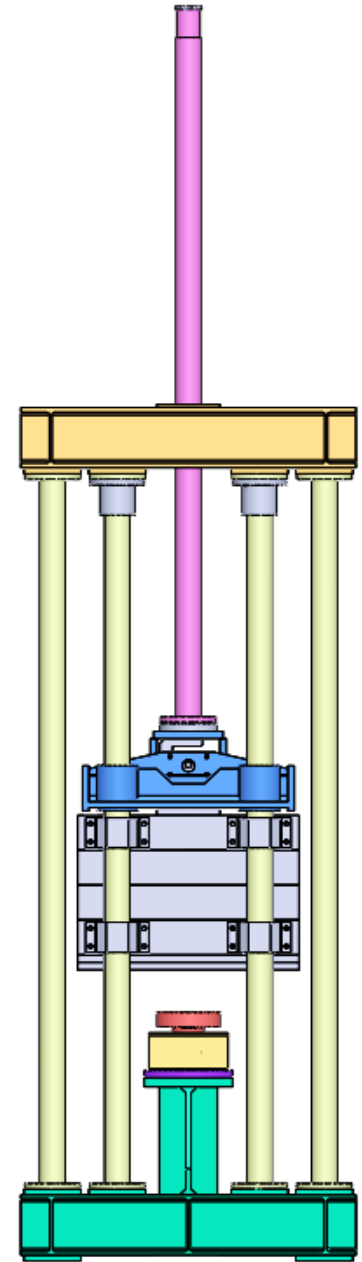

Side View

8. High Pressure Vessel Facility

Impact Test Rig



Front View of Impact machine & Hydraulic System



Side View of Impact machine & Hydraulic System

Specifications :

Maximum Weight: 2000 kg

Maximum Pressure : 50 MPa

Stroke Length : 1 m