



Computational **Multi**-Fluid Dynamics Lab.

Research activities and plans

March 2023

June Kee Min



June Kee Min, Ph.D. (Professor)

▪ Education

- 1999 Ph.D. Dept. of Mechanical Engineering, KAIST
- 1990 M.S., Dept. of Mechanical Engineering, KAIST
- 1988 B.S., Dept. of Naval Architecture, Seoul National University

▪ Professional experiences

- 2017 ~ Present: Pusan National University, School of Mechanical Engineering, Professor
- 2021 ~ 2022: University of Florida, Visiting Professor
- 2013 ~ 2017: Pusan National University, Rolls-Royce University Technology Centre, Assistant Professor
- 2008 ~ 2013: Pusan National University, Rolls-Royce University Technology Centre, Research Professor
- 2003 ~ 2008: Samsung Electronics Co. LTD., Principal Engineer
- 2000 ~ 2002: LG Electronics Inc., Senior Engineer
- 1990 ~ 1993: LG Electronics Inc., Junior Engineer

▪ Projects (On-going)

- National Research Foundation of Korea (NRF)
- Korea Institute of Energy Technology Evaluating and Planning (KETEP)
- Agency for Defense Development (ADD)
- Rolls-Royce plc
- LG electronics
- Research Institute of Industrial Science & Technology (RIST)
- Daewoo Shipbuilding & Marine Engineering (DSME)



- **CFD**
 - ✓ Computational Fluid Dynamics
- **CMFD**
 - ✓ Computational Multi-Fluid Dynamics
- **Multi-**
 - ✓ Multi-phase
 - ✓ Multi-Physics
 - ✓ Multi-Objective
 - ✓ Multi-Disciplinary

Research area

“Advanced CFD modeling and thermal management technology for future power-energy system”

•New research area

•Industrial applications

- Foaming
- Freezing
- Frosting/Condensation
- Heat Exchanger
- Fluid machinery

•CFD for multi-phase flow

- HVAC&R
- Cryogenic
- Multi-phase design tool
- Nuclear system
- 3D CFD multi-phase model



•Advanced numerical modeling

- Fluid-Structure Interaction
- HX shape optimization
- Aero-thermal topology optimization
- Machine learning(ANN/CNN/GAN)

•Thermal management technology

- Novel heat exchanger (future power-energy system)
- Electro-chemical system
- Cryogenic system
- Heat Pipe & Integrated HM project
- Oil de-congealing
- Design tools
- Gas turbine (HPHT)
- Battery thermal management

- **Thermal management technology**
- Advanced numerical model for aero-thermal system
- CFD for multi-phase flow
- Research programs

Why thermal management technology?

- In conventional power system, **40-80% energies are wasted.**
- The development of **Thermal Management Technology** is a key for the future energy/power system.

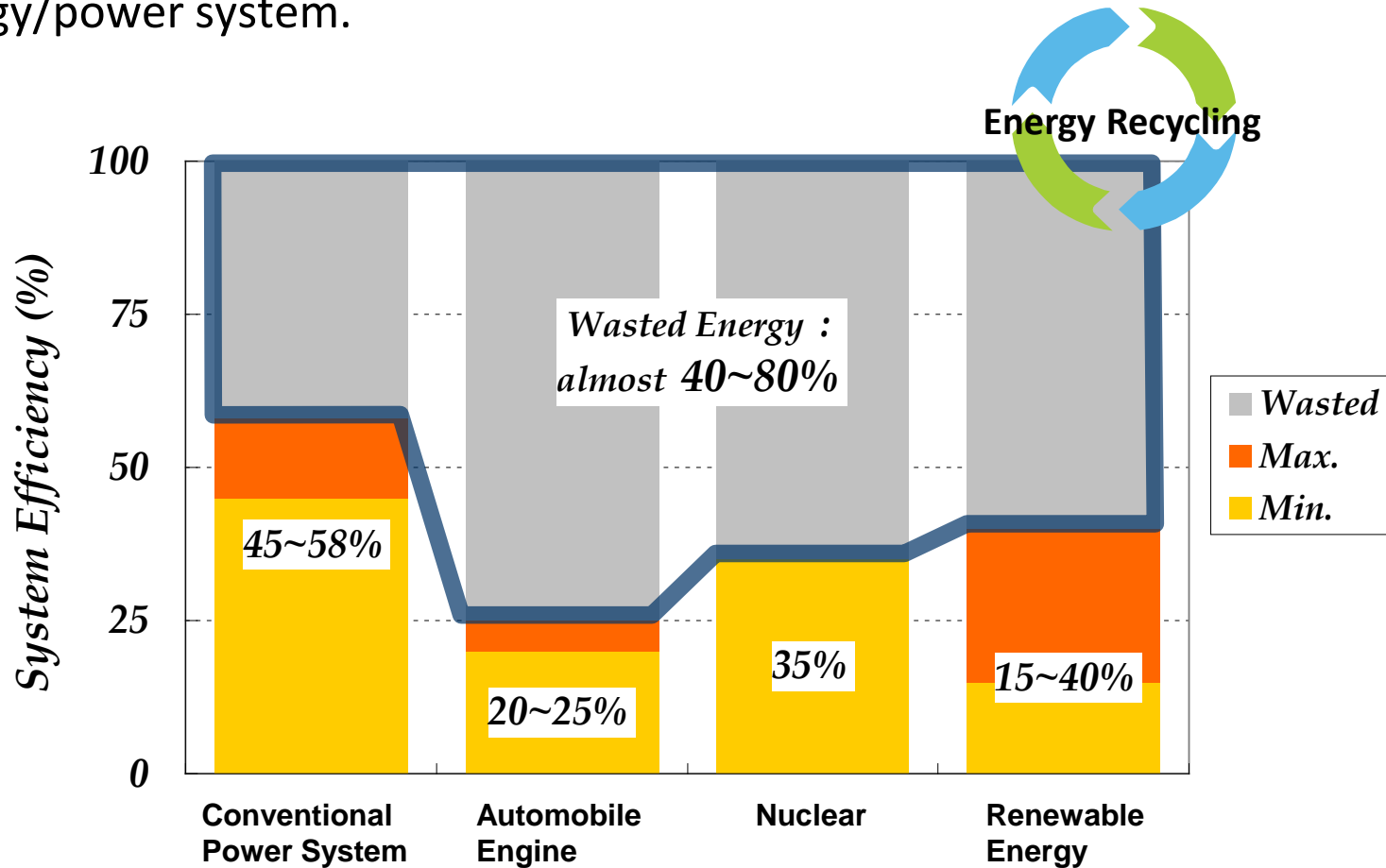

Application of thermal management tech

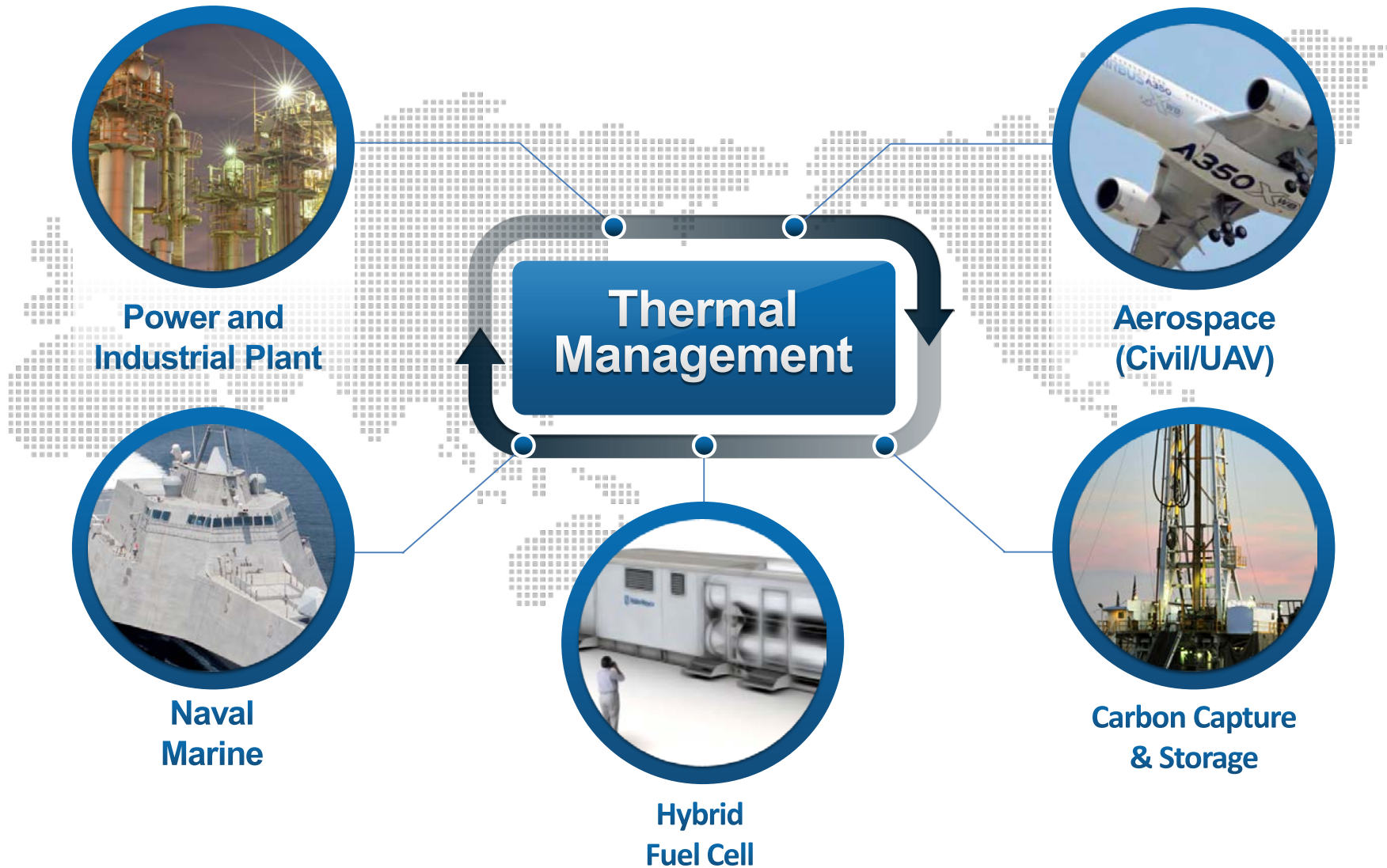

Advanced gas-turbine cycle for aero-engine

- **FlightPath 2050 goals (2011)**

: Relative to the capabilities of typical new aircraft in 2000.

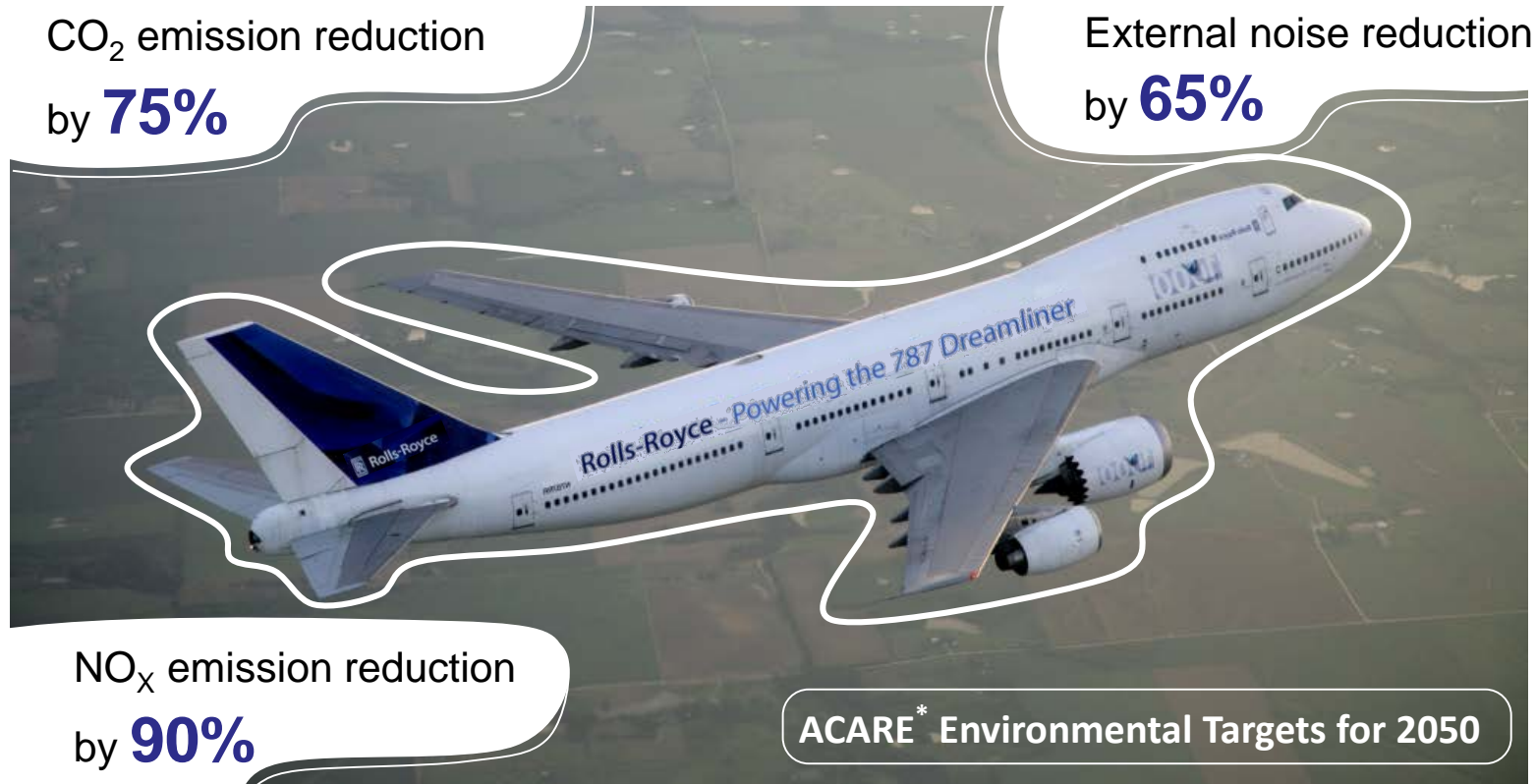

*Advisory Council for Aerospace Research in Europe

Advanced gas-turbine cycle for aero-engine

- Development of **ultra-light and highly reliable novel thermal management system** for **HTHP condition**.

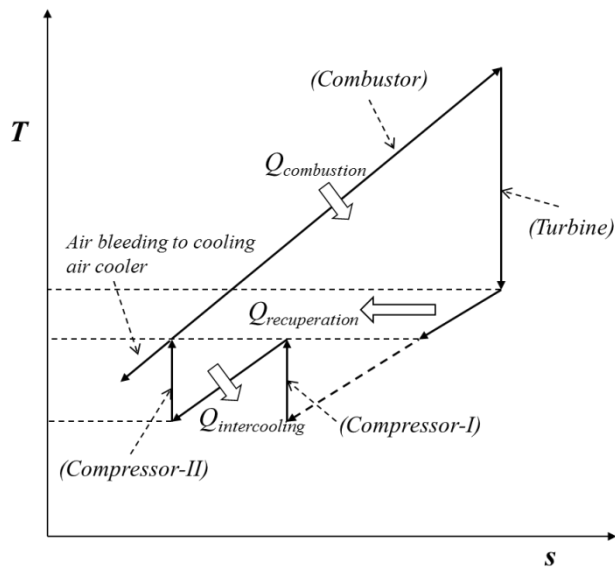

Advanced Brayton cycle with recuperator, intercooler and cooling air cooler

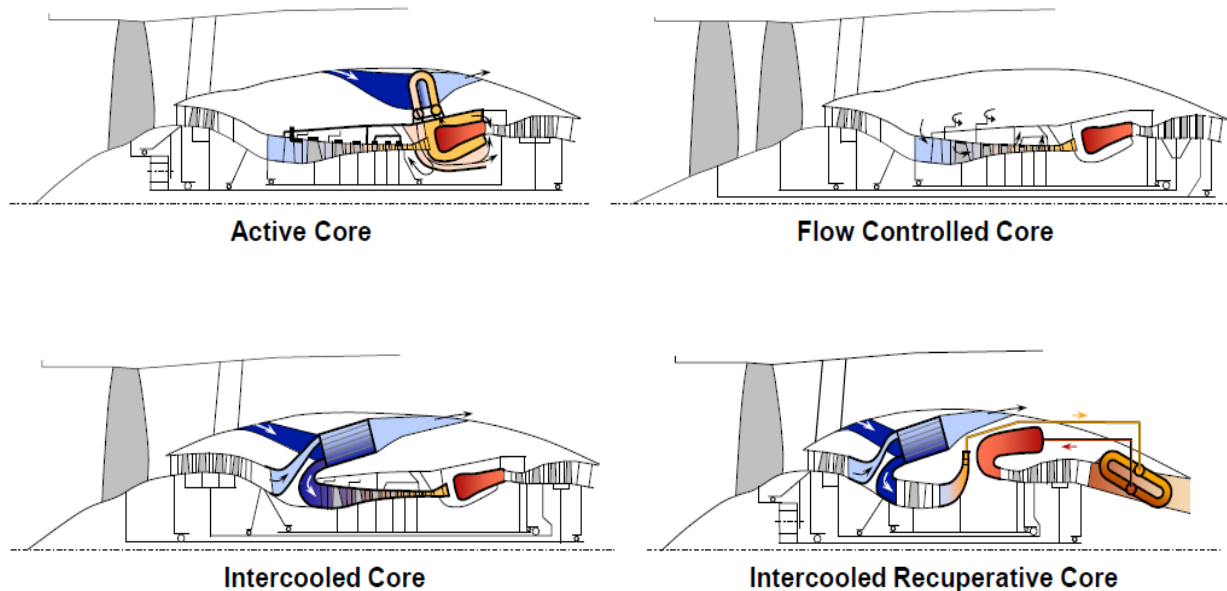

Various concepts for aero-engines (EU-FP NEWAC programme)

Novel HXs: gas turbine application

- Intercooler for aero-engine (EU-NEWAC programme)

- Ultra-fan oil cooling (EU-NEWAC programme)

- Heat loading

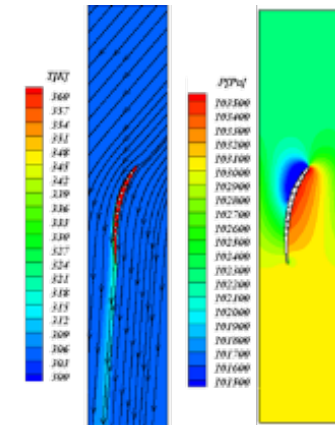
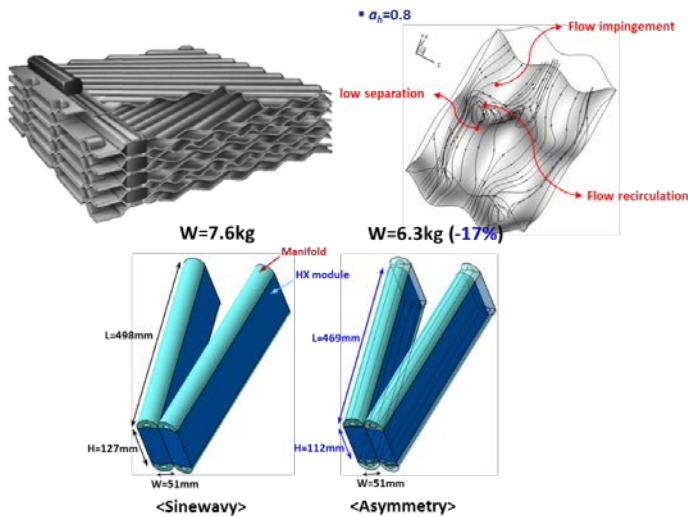
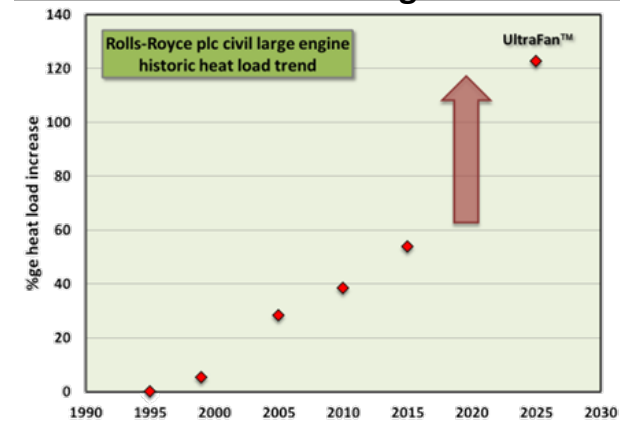
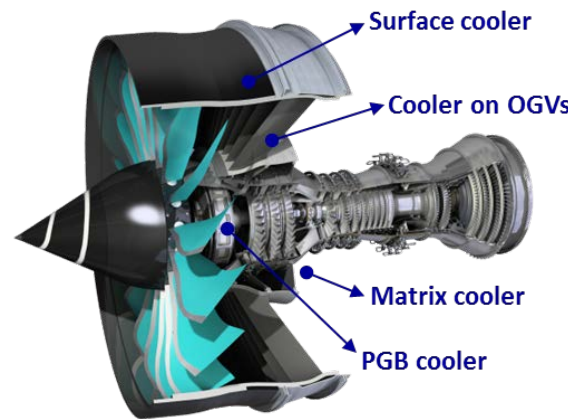
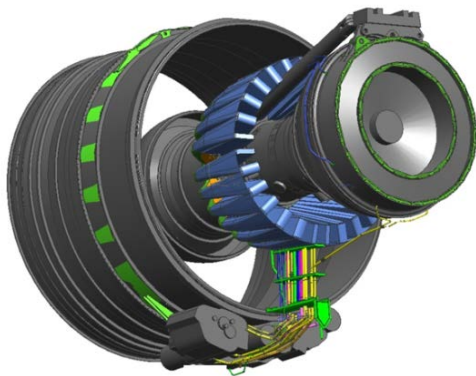

Novel HXs: gas turbine application

- Surface cooler
(Trent-XWD aero-engine)

- GT Case colling
(MOD UAV-project)

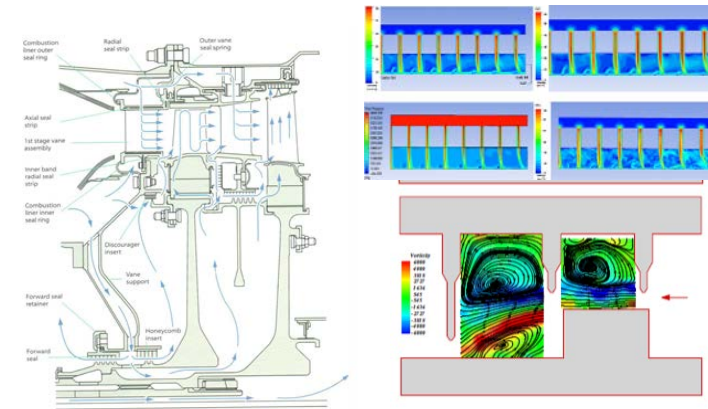
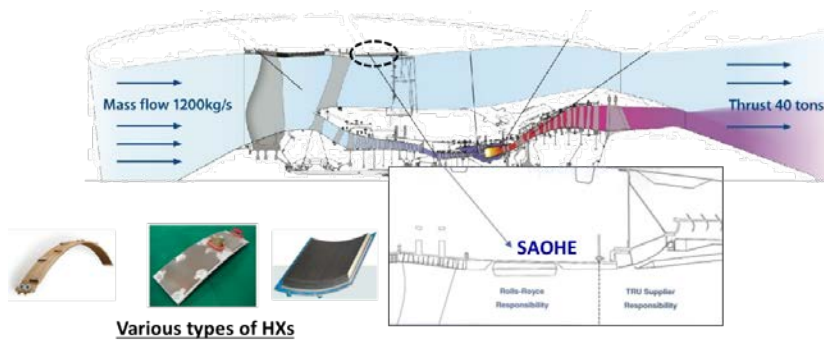

- Slanted pin-fins

- BL technique

- Turbine blade cooling for power gen

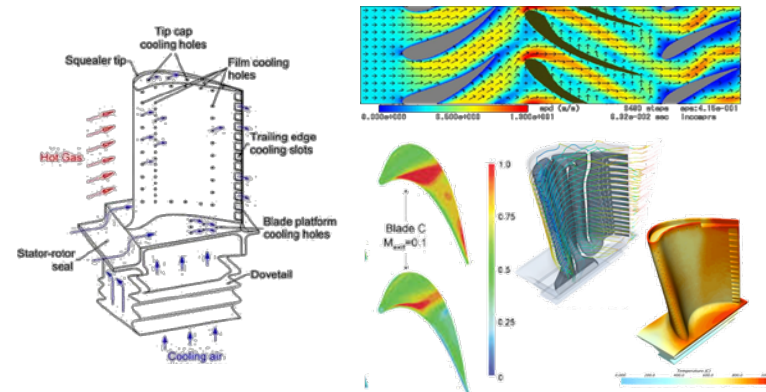
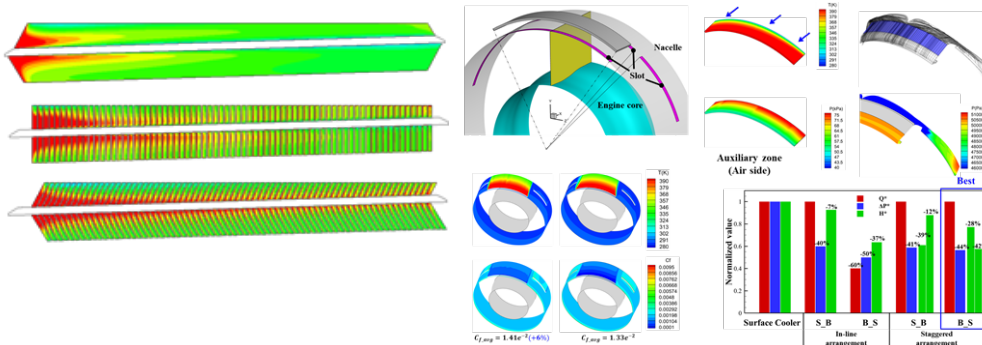

Novel HXs: In-house design tools

• Ranking program (HXRP)

▪ HXRP (latest version: HXRP v3.0)

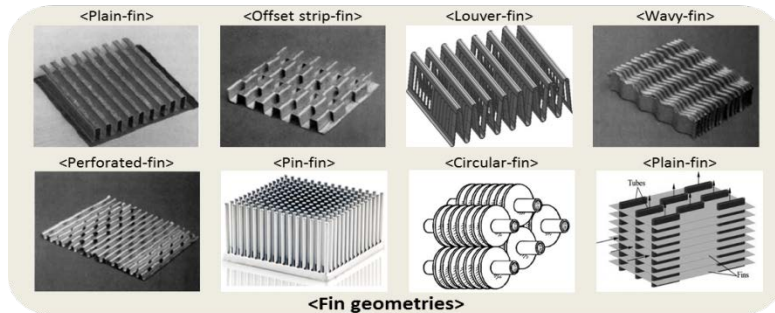
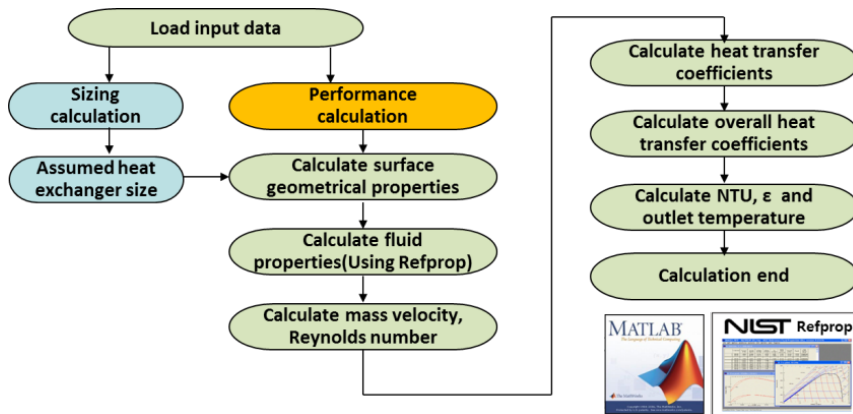

• 1D network program

▪ Flow network analysis

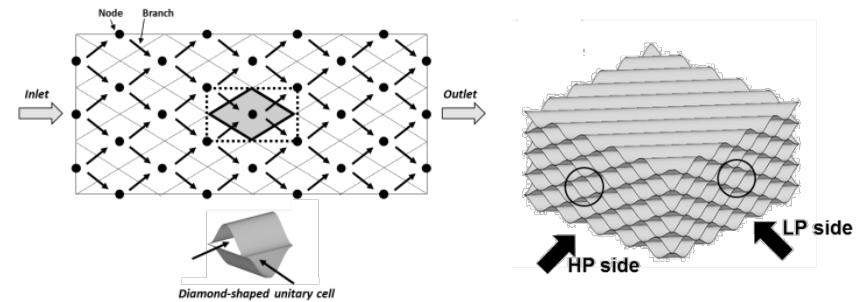

▪ Two-phase flow

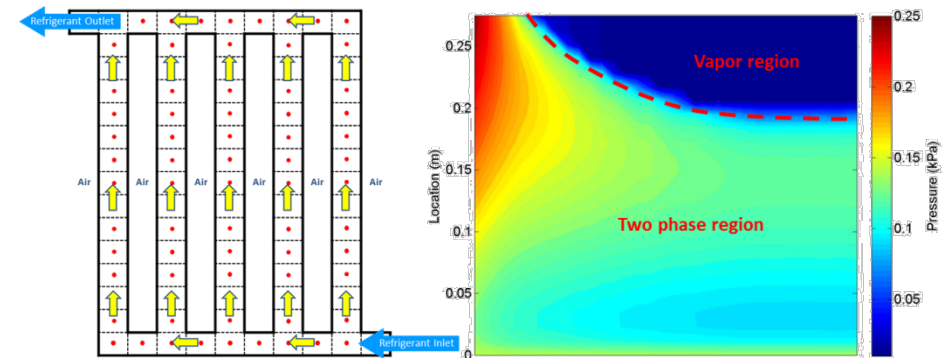

<MCHEx matrix in 1D code>

Novel HXs: New heat sink

- Slanted-pin-fin cooler under a high-speed-condition

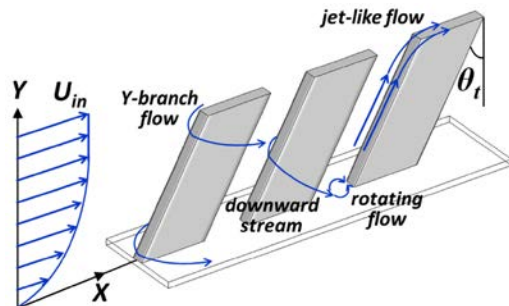
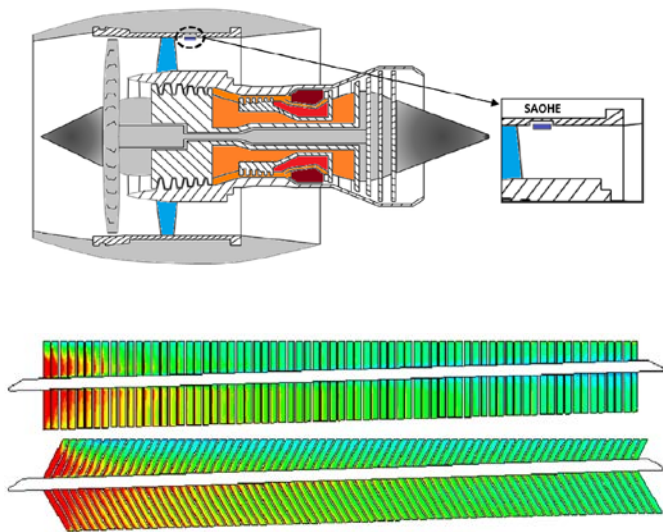

- Slanted-pin fins mounted on a vertical plate

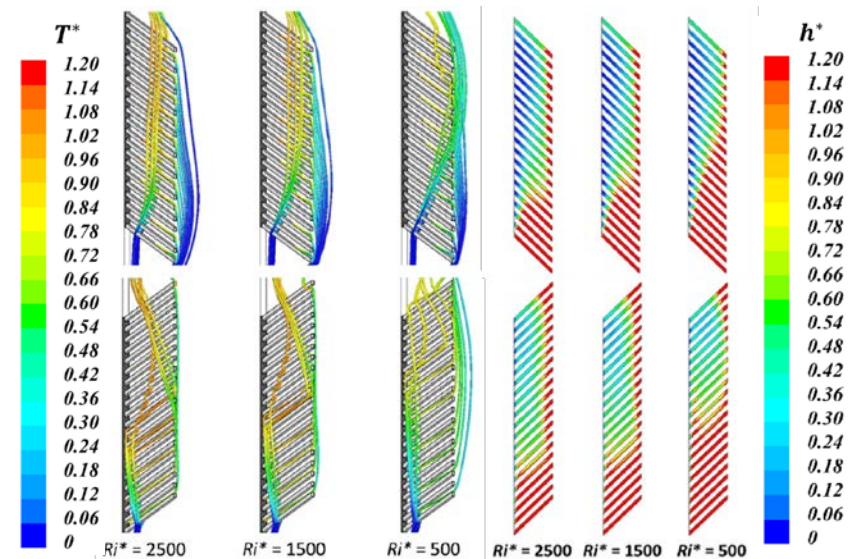
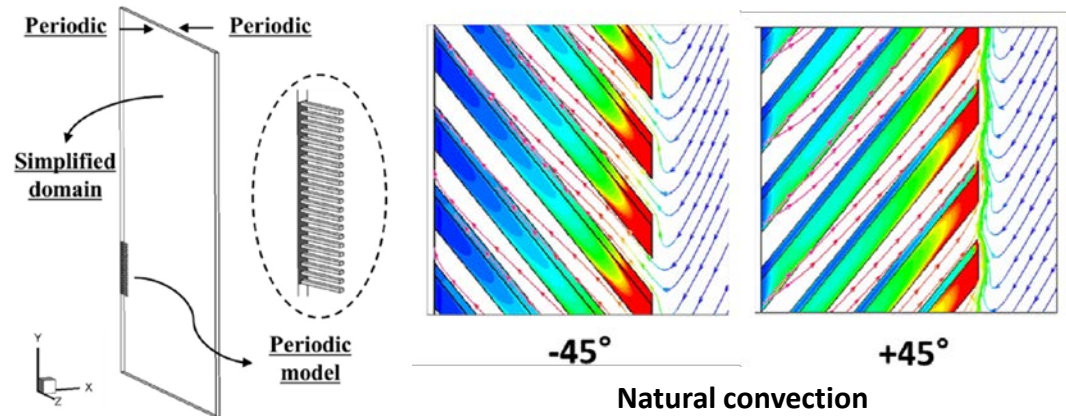

Mixed convection

Novel HXs: Cryogenic (below -160°C)

- Thermal design for multi-stream/multi-pass HX



Engineering application: LNG tanker

- Printed Circuit Heat Exchanger(PCHE) under supercritical conditions

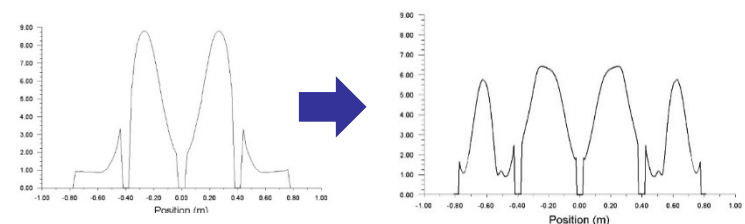
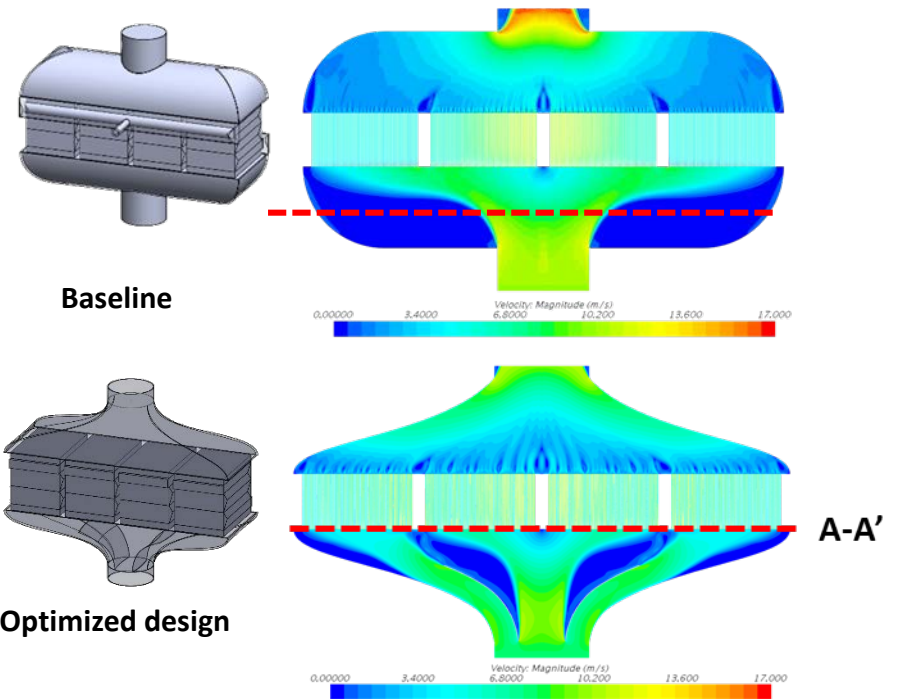

HXs: New challenges

• Oil-congealing inside a heat exchanger (Transient temp variation from -40 °C)

• Improved HX CFD models

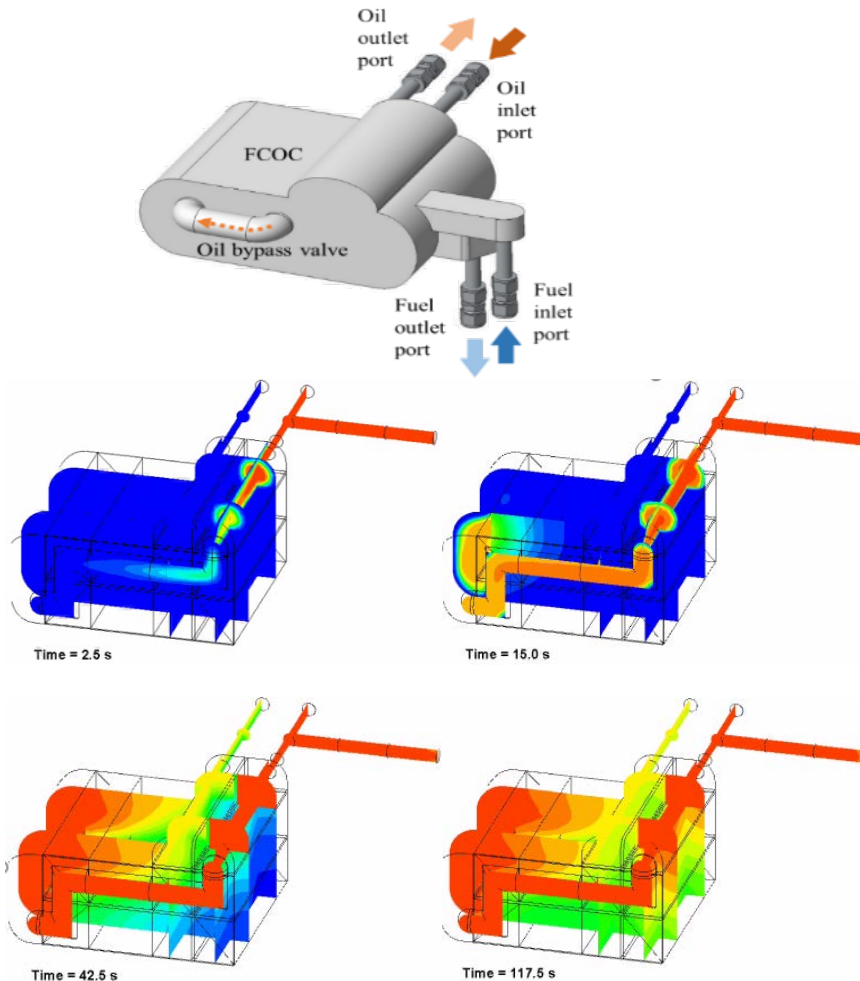

• Experiment

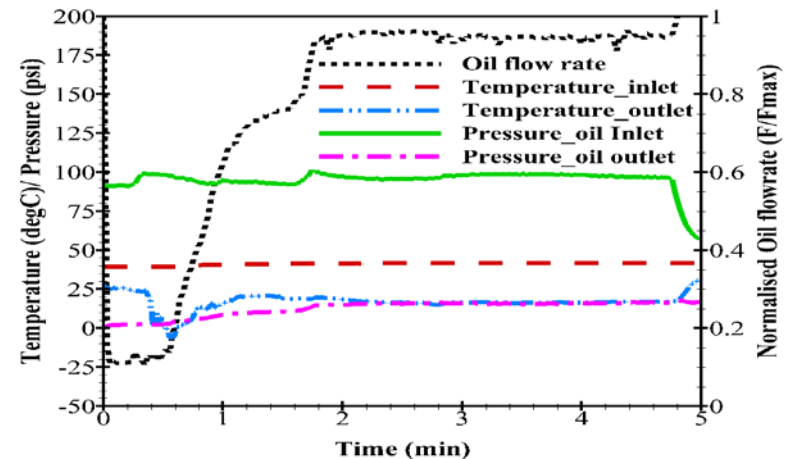
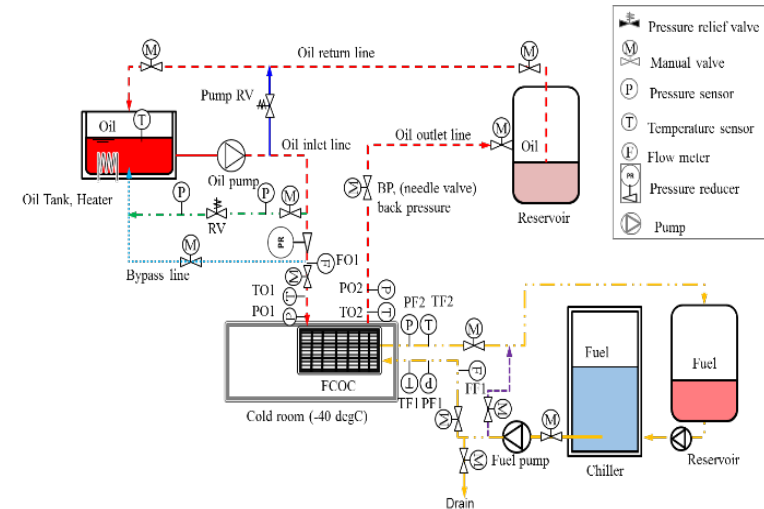

New challenges

- Design tech for Heat Pipe application
(Harsh operating condition and large-scale)

- 3D CFD

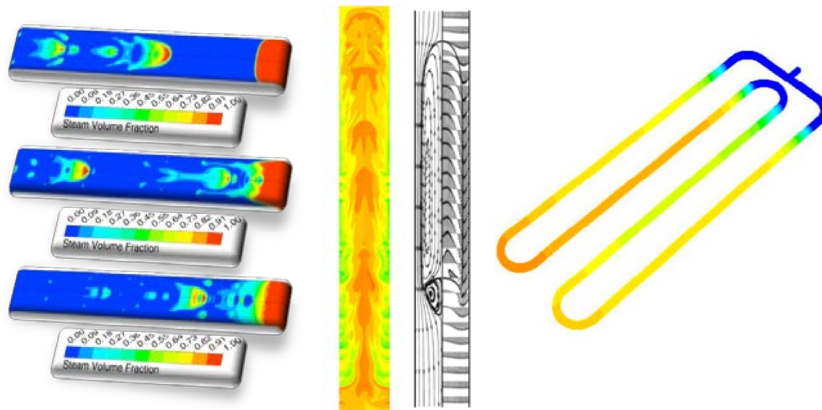

- Integrated heat management system
(For future aircraft thermal management)

- Increased electrification

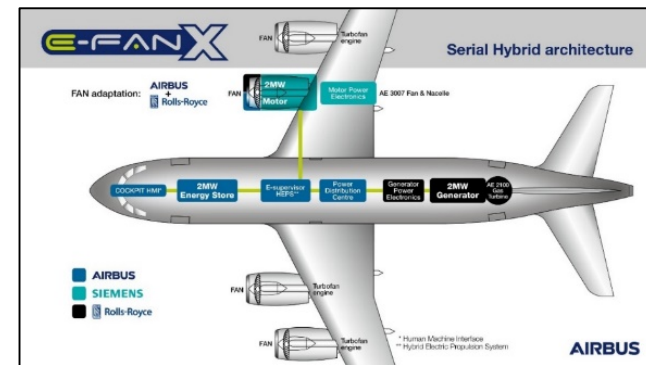

- Airframe surface heating for HX integration concept



- Performance correlations

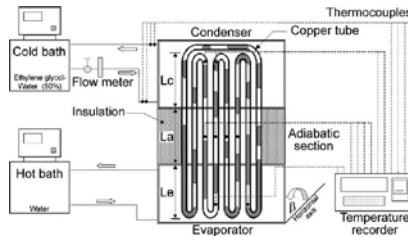
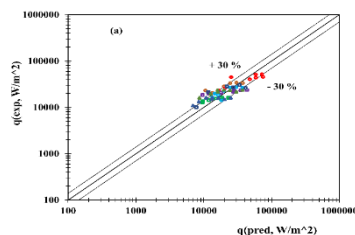

- Water, $d_i = 2 \text{ mm}$, $\beta = 0 - 90$, $\phi = 50 \%$, $N > N = 16$, $Q = 550 \text{ W}$ [8]
- Water, $d_i = 2 \text{ mm}$, $\beta = 0 - 90$, $\phi = 50 \%$, $N > N = 16$, $Q = 1100 \text{ W}$ [8]
- R123, $d_i = 2 \text{ mm}$, $\beta = 0 - 90$, $\phi = 50 \%$, $N > N = 23$ [8]
- R123, $d_i = 2 \text{ mm}$, $\beta = 0 - 90$, $\phi = 50 \%$, $N > N = 16$, $Q = 550 \text{ W}$ [8]
- Water, $d_i = 2 \text{ mm}$, $\beta = 0 - 90$, $\phi = 50 \%$, $N > N = 23$ [8]
- R123, $d_i = 2 \text{ mm}$, $\beta = 0 - 90$, $\phi = 50 \%$, $N > N = 16$, $Q = 951 \text{ W}$ [8]
- Ethanol, $d_i = 2 \text{ mm}$, $\beta = 0 - 90$, $\phi = 50 \%$, $N > N = 23$ [8]
- Ethanol, $d_i = 2 \text{ mm}$, $\beta = 0 - 90$, $\phi = 50 \%$, $N > N = 16$ [8]

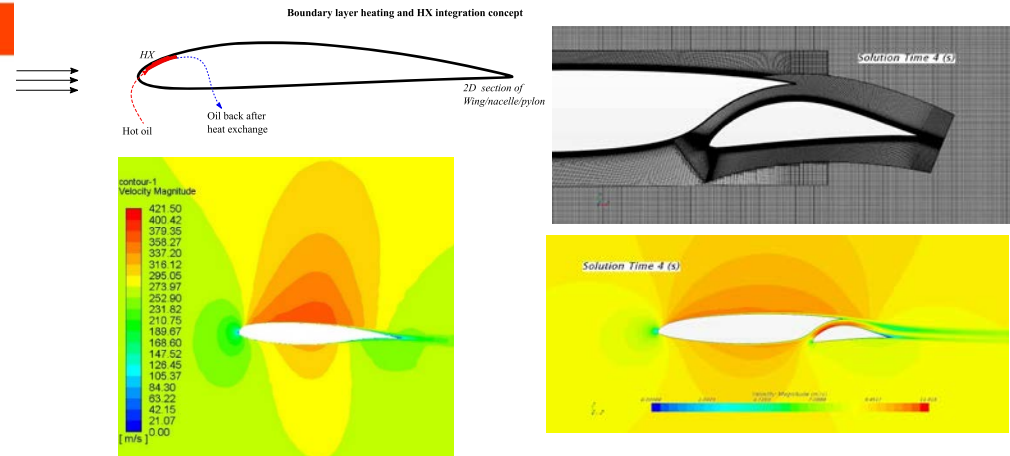

Thermal management for electro-chemical system

• Thermal management inside a battery system (ESS): Molten NAS battery, 300-350°C

• Temperature uniformity inside a ESS module

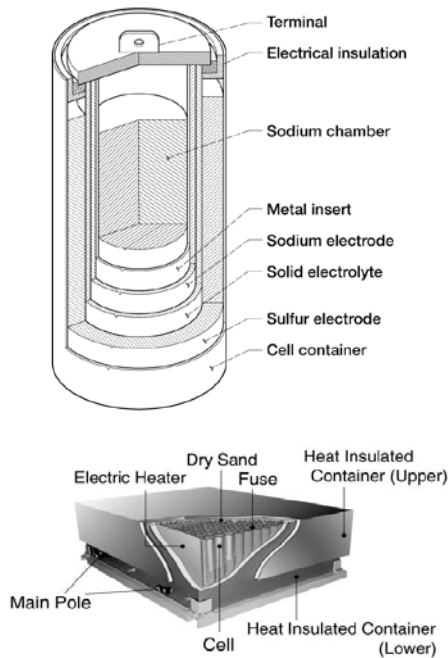

Molten sodium-sulfur battery cell and module

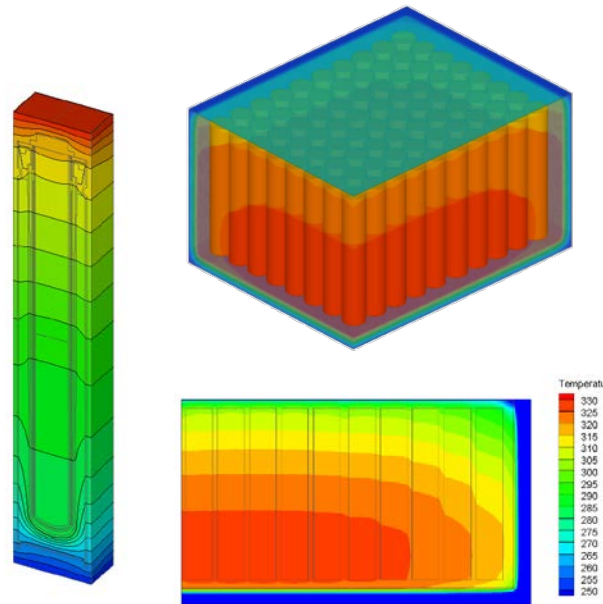

Temperature distribution inside the module during discharging/charging cycle

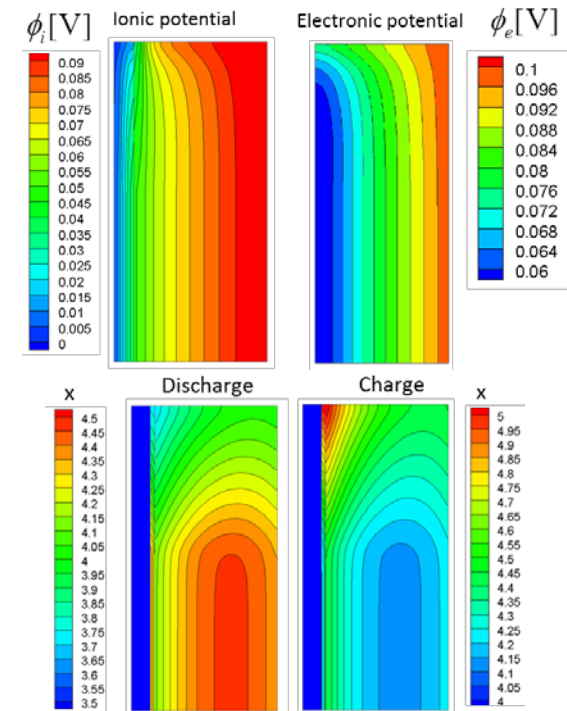

Potential and reactant distribution inside the cathode

Thermal management for electro-chemical system

• Safety analysis methodology : temperature rise in the cell under failure mode (crack).

• Accident report in ESS, Japan (2011)

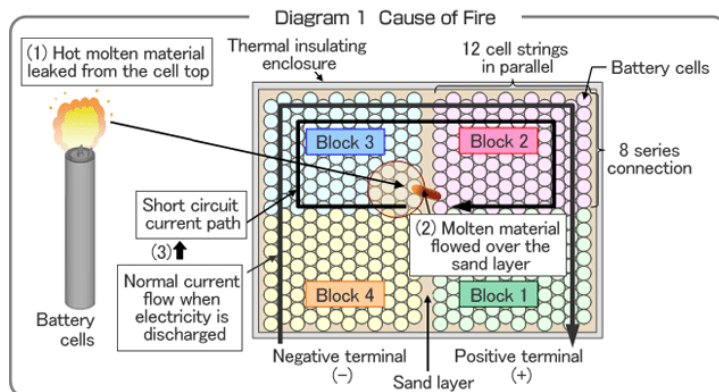

• Leak flow model

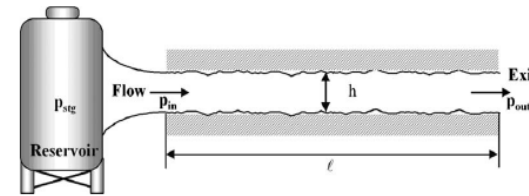
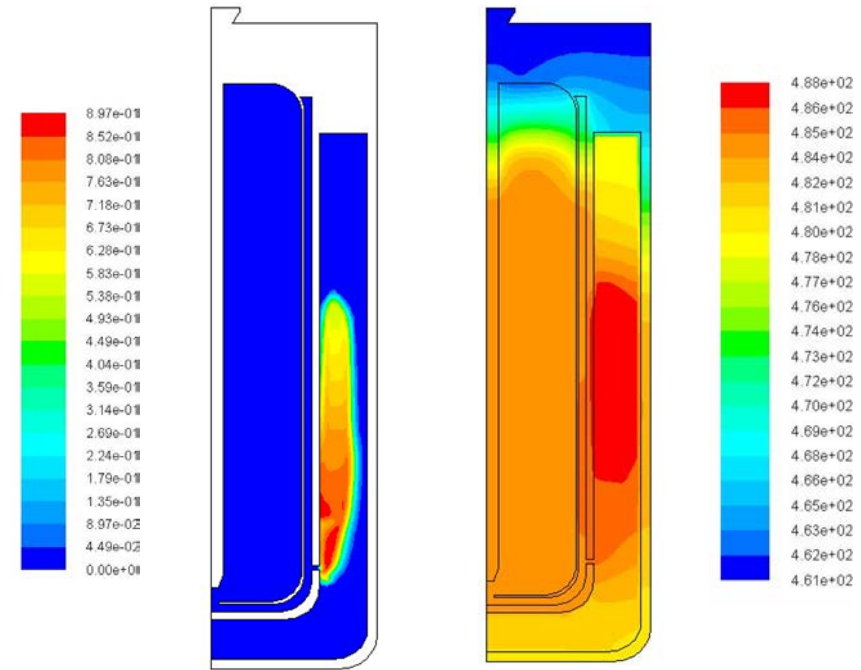

Fig. 1 Flow model in a narrow crack



Mass fraction of reactant

Temperature distribution

Thermal management for electro-chemical system

• Thermal management inside a battery system (ESS): Na-NiCl₂, 190-200°C

- Thermal design of ESS hotbox considering novel manufacturing process

Temperature distribution

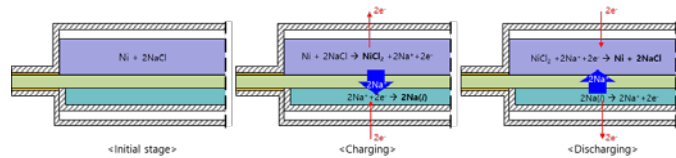
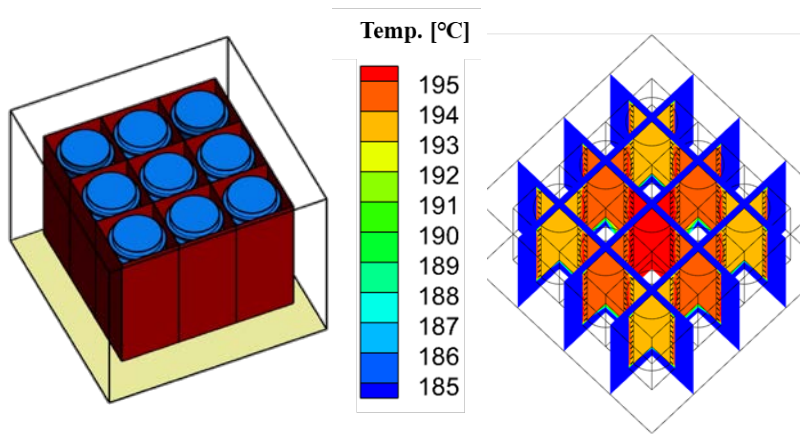

Electro chemical reaction

3D CFD

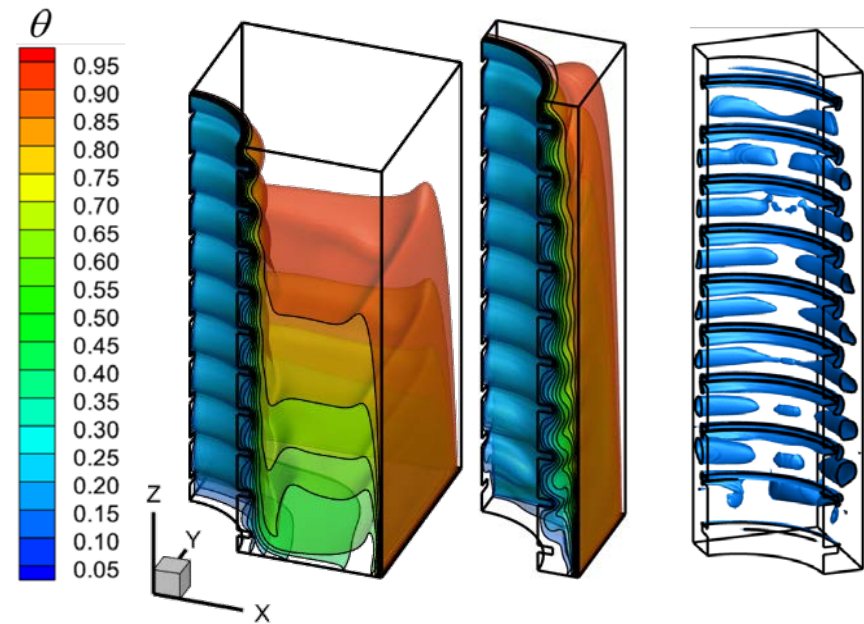

-
- Thermal management technology
 - **Advanced numerical model for aero-thermal system**
 - CFD for multi-phase flow
 - Research programs

Fluid-Structure Interaction

- Vortex shedding and deformations of U-shaped mini-tube for HX application
- A study on a flexible wing with up-down vibration in a pulsating flow of cooling air to improve heat transfer efficiency

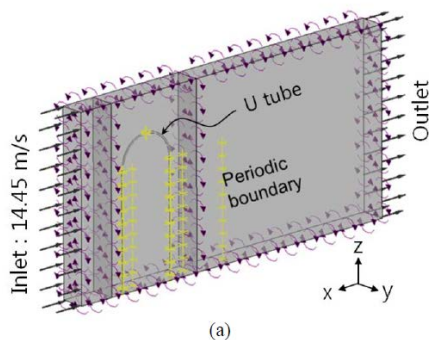

(a)

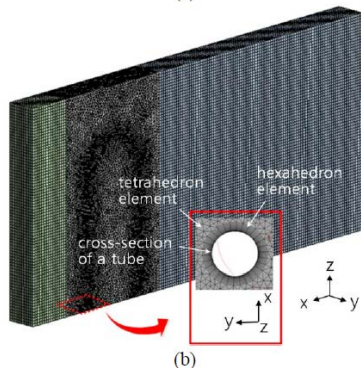

(b)

Problem set-up

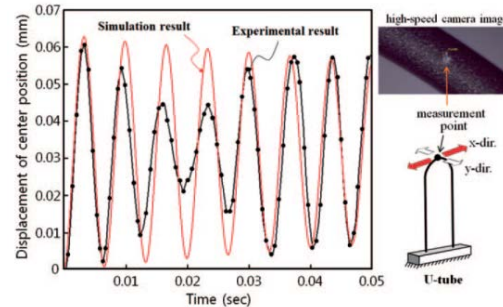
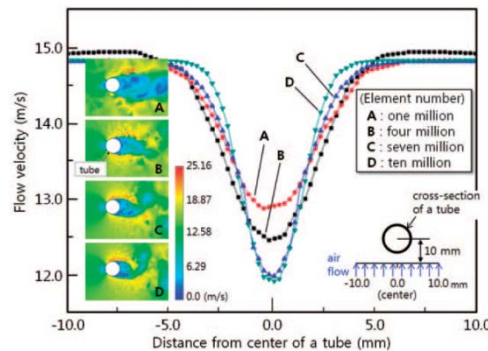

Comparison with experiment

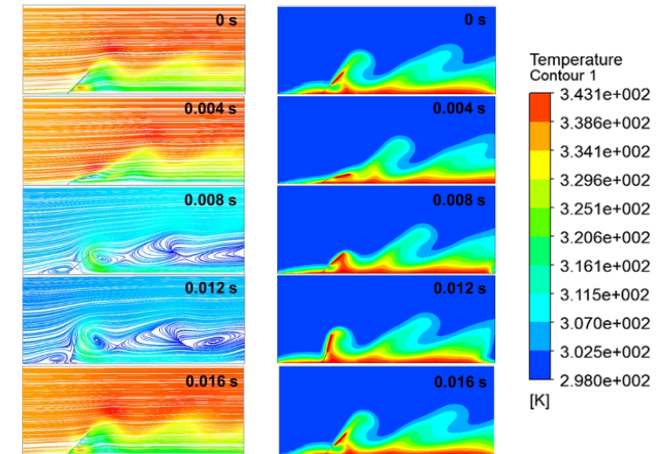
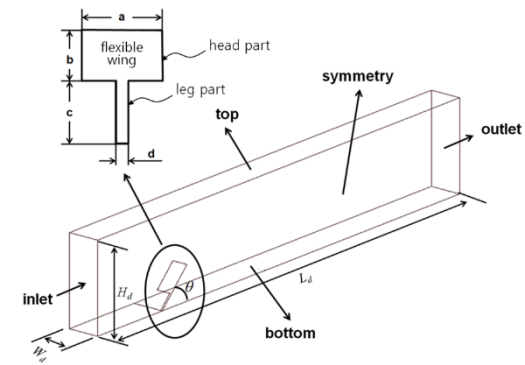

Flow and temperature field

Artificial Neural Network

• Performance correlations for Heat Pipe using ANN

- Imitating and applying the utilities of human brain neurons to predict the heat transfer of heat pipes. Used for highly non-linear predictions within an identified operating space.
- **Faster speed**, high flexibility and high accuracy in prediction within the identified space
- **Input layer : Heat flux and fluid filling ratio, Output layer : thermal resistance**

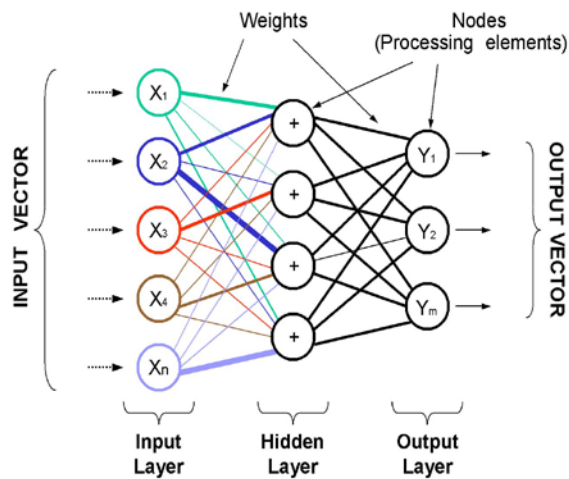

ANN neuron layout

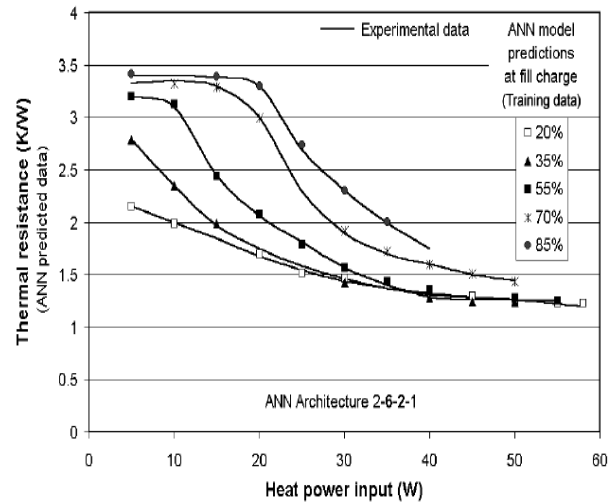

ANN prediction of experimental data

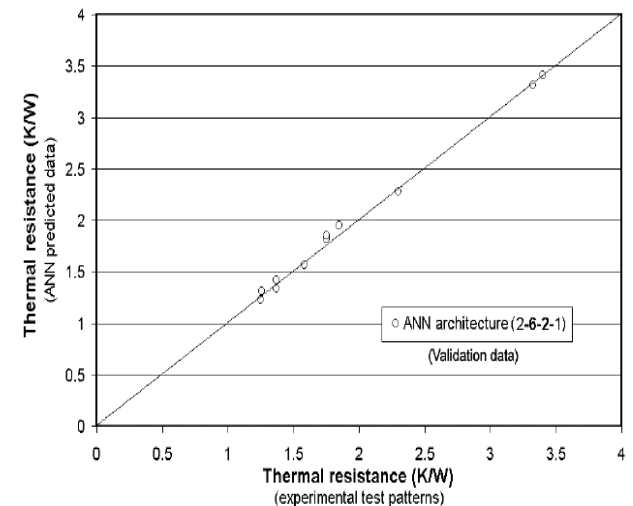

ANN validation of experimental data

Challenges: Condensation application

• Development of ANN model

• ANN data processing

ID	Surface	Material	Location (x, y, z)	Area (m²)	Volume (m³)	Mass (kg)	Color	Material
1	Condenser coil (horizontal)	Aluminum	0, 0, 0	0.1	0.001	0.0027	Blue	Aluminum
2	Condenser coil (vertical)	Aluminum	0, 0, 0	0.1	0.001	0.0027	Blue	Aluminum
3	Condenser coil (diagonal)	Aluminum	0, 0, 0	0.1	0.001	0.0027	Blue	Aluminum
4	Condenser coil (curved)	Aluminum	0, 0, 0	0.1	0.001	0.0027	Blue	Aluminum
5	Condenser coil (flat)	Aluminum	0, 0, 0	0.1	0.001	0.0027	Blue	Aluminum
6	Condenser coil (ribbed)	Aluminum	0, 0, 0	0.1	0.001	0.0027	Blue	Aluminum
7	Condenser coil (finned)	Aluminum	0, 0, 0	0.1	0.001	0.0027	Blue	Aluminum
8	Condenser coil (smooth)	Aluminum	0, 0, 0	0.1	0.001	0.0027	Blue	Aluminum
9	Condenser coil (rough)	Aluminum	0, 0, 0	0.1	0.001	0.0027	Blue	Aluminum
10	Condenser coil (textured)	Aluminum	0, 0, 0	0.1	0.001	0.0027	Blue	Aluminum

• Model development & prediction

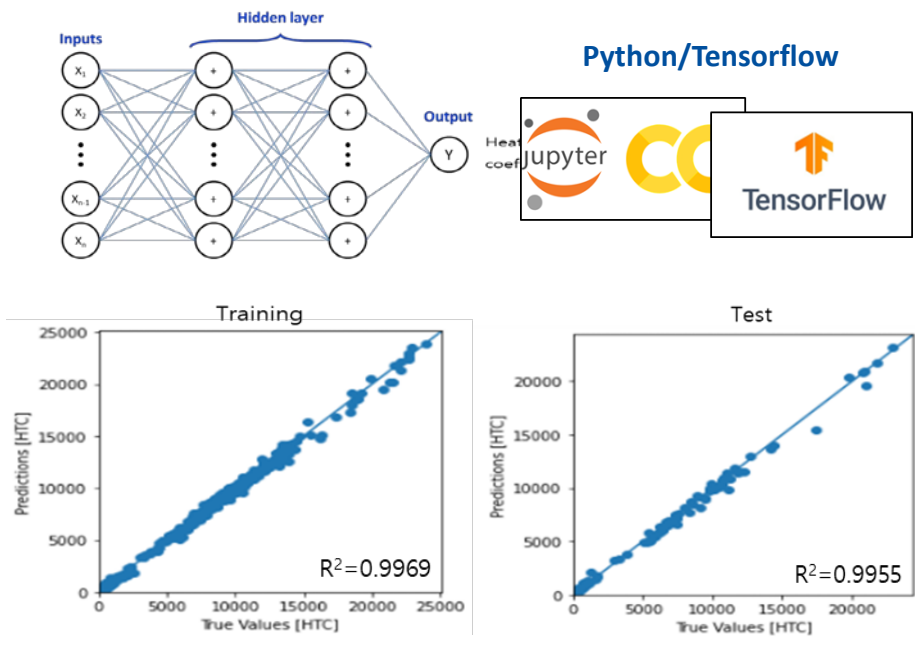

• CFD based on FVM

• CFD condensation results

Lee model (evaporation & condensation)

$$\dot{m}_v = r \alpha_v \rho_v \frac{T - T_{sat}}{T_{sat}}$$

tuning parameter from ANN prediction

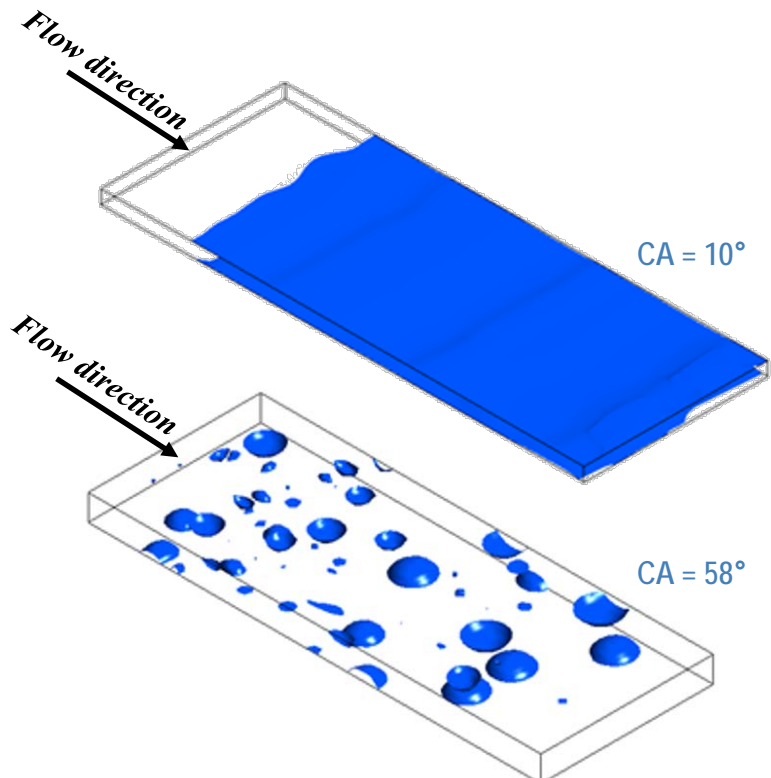

Challenges: Topology optimization

• Topology optimization in thermo-hydraulic system

• Finite-Volume based topology optimization

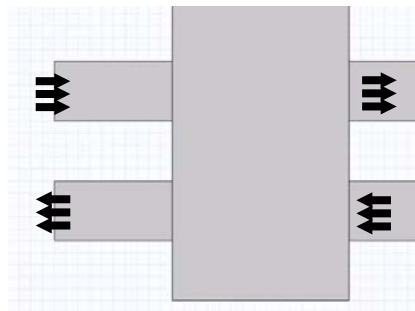

Duct design

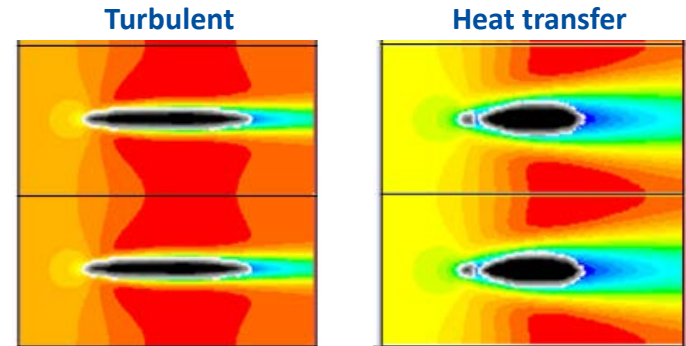
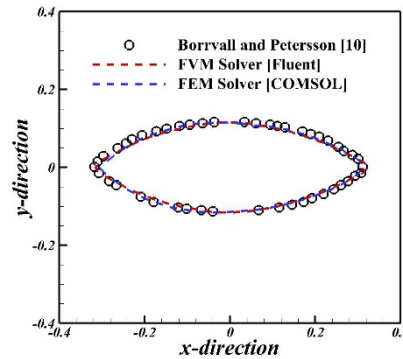

FVM based topology optimization ([In-house code](#))

• Application for aero-thermal topology optimization

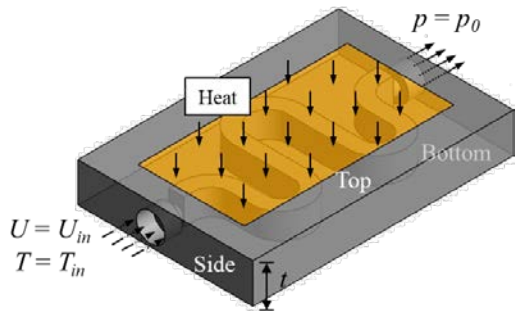

Path design for liquid-cooled heat sink

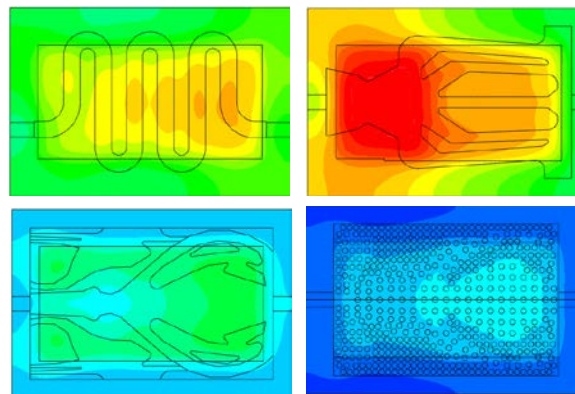

Temperature distribution

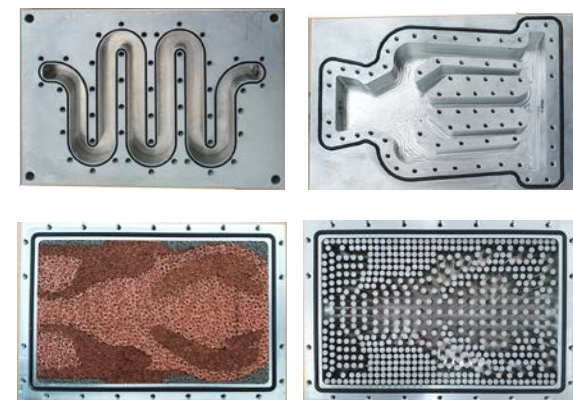

Manufacture

Challenges: Optimization for industrial

• Shape optimization of HXs

• HPHT conditions (1000K 50 bar)

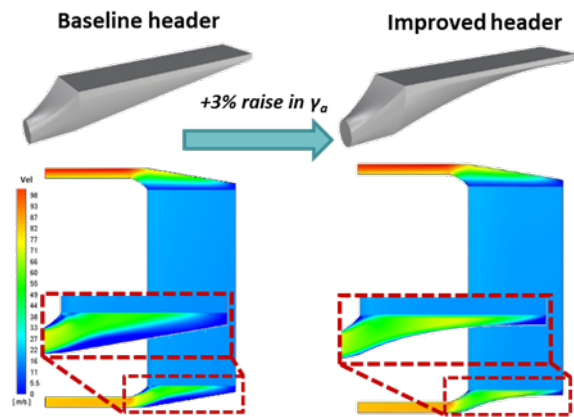

• Experiment

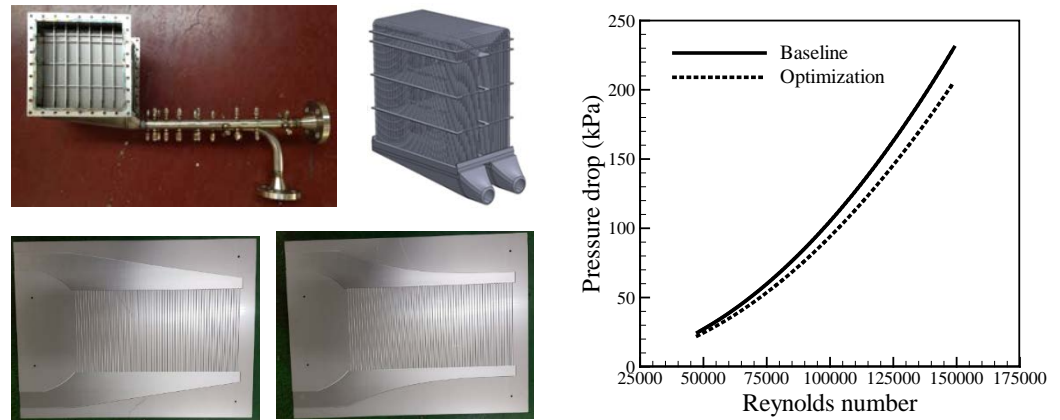

• Cryogenic conditions (below -100°C)

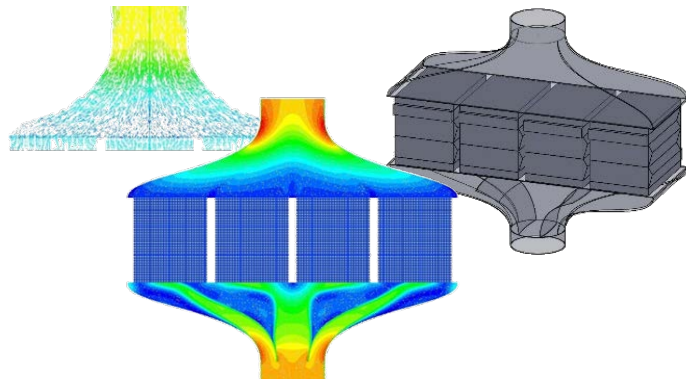

• Time-dependent HX evaluation

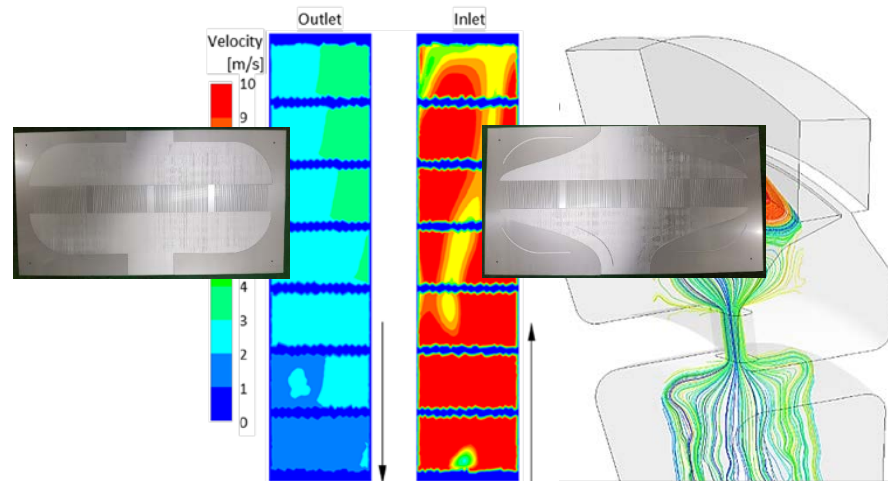

Challenges: OpenFOAM base solver dev.

• Applications for OpenFOAM built-in function & solver

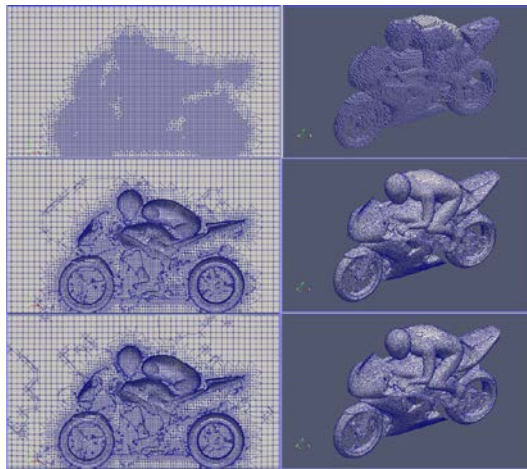

[Mesh generation]

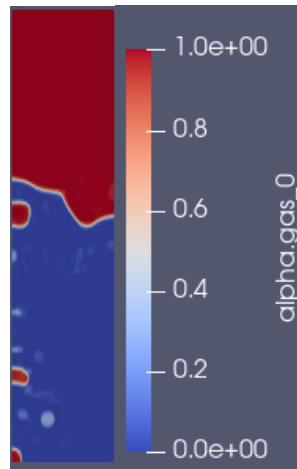

[Phase change: Boiling]

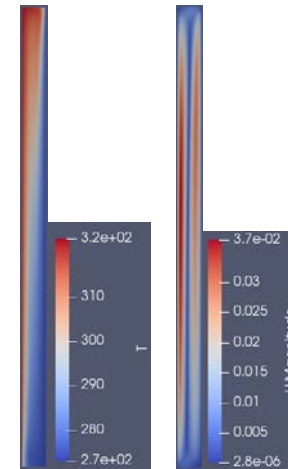

[Natural convection: Boussinesq approximation]

• Advanced solver development

$$\alpha = \alpha_{\min} + (\alpha_{\max} - \alpha_{\min})(1 - \gamma)^P$$

$$\gamma = \begin{cases} 0 & (\text{solid}) \\ 1 & (\text{fluid}) \end{cases}$$

$P = 3$ (usually)

$$\phi = \int_{\Omega} \left\{ \frac{1}{2} \mu \left(\frac{\partial u_i}{\partial x_j} + \frac{\partial u_j}{\partial x_i} \right) \left(\frac{\partial u_i}{\partial x_j} + \frac{\partial u_j}{\partial x_i} \right) + \alpha(\gamma) u_i u_i \right\} d\Omega$$

$$\frac{d\phi}{d\gamma} \approx \frac{\partial \alpha_2}{\partial \gamma} = -P(\alpha_{\max} - \alpha_{\min})\gamma^{P-1}$$

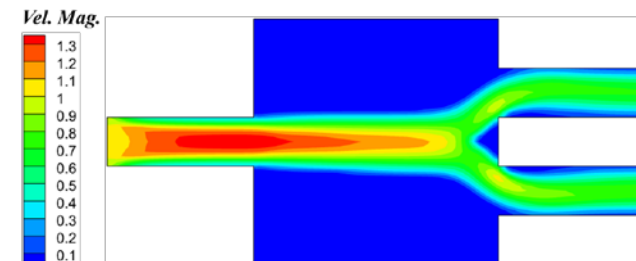
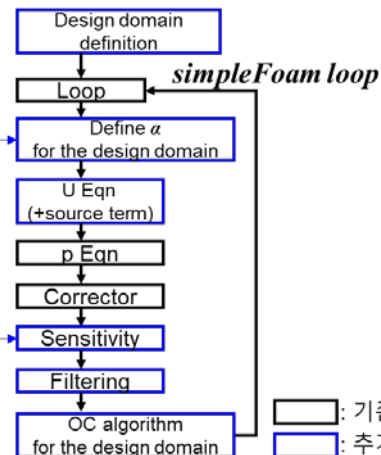

- Thermal management technology
- Advanced numerical model for aero-thermal system
- **CFD for multi-phase flow**
- Research programs

- 3D CFD on the mal-distribution in multi-phase HX
- Development of improved phase change model
- Prelim code : 0D lumped model and 1D network solver



Actual header geometry

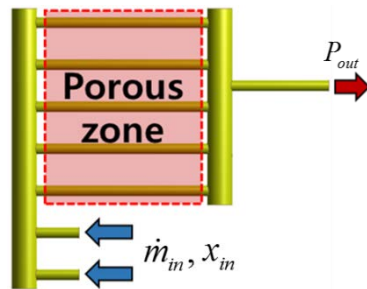

Equivalent HX model

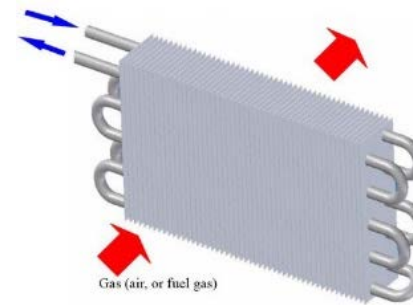

Tube-fin multi-phase HX

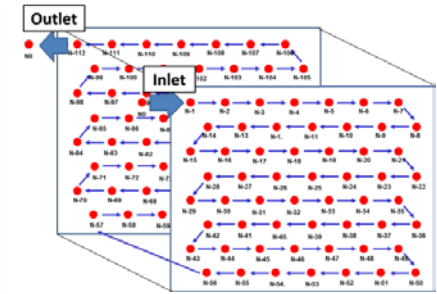

1D network model

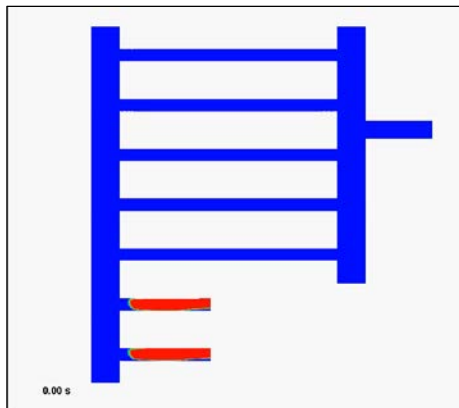

Volume fraction contour (without phase-change)

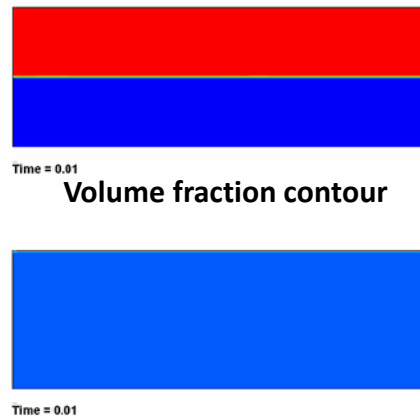

Temperature contour

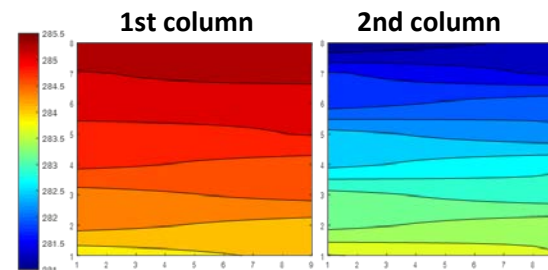

Temperature distribution of HX

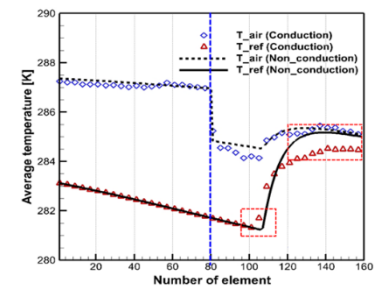

Average temperature [K] vs Number of element

Cryogenic: Liquefaction

- CFD modeling for HXs, Mixers, Manifolds

- Cryogenic HX

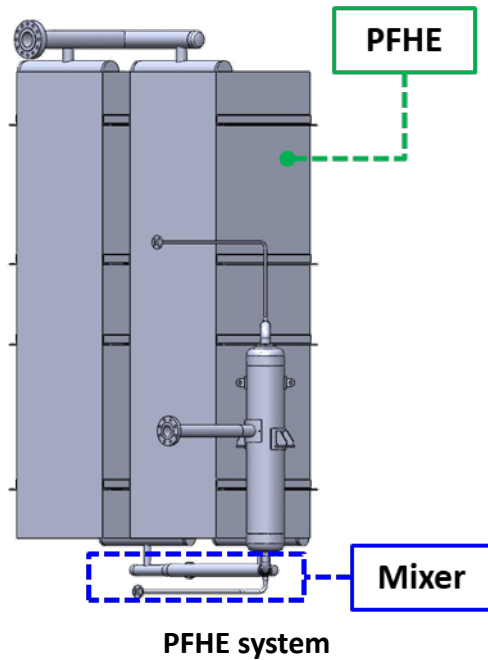

Visualization of internal HX flow pattern

- Full-scale analysis

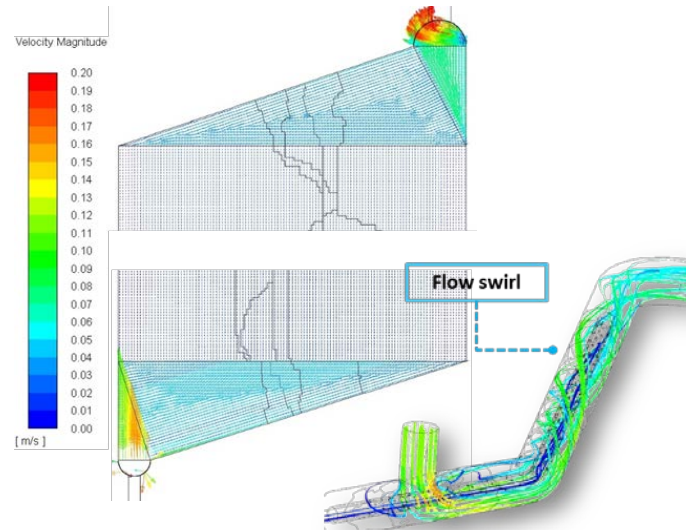

- Equivalent model development

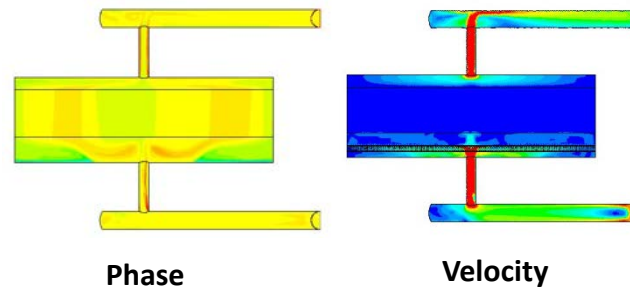

- Improved multi-phase model

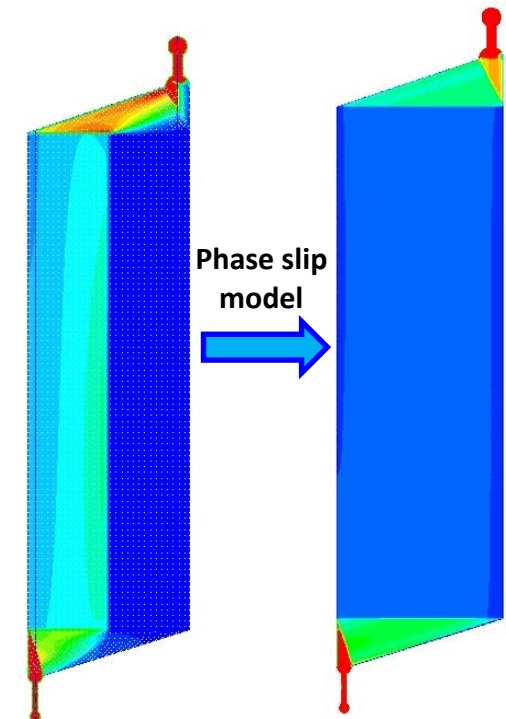

Nuclear system

• Numerical analysis of the Condenser

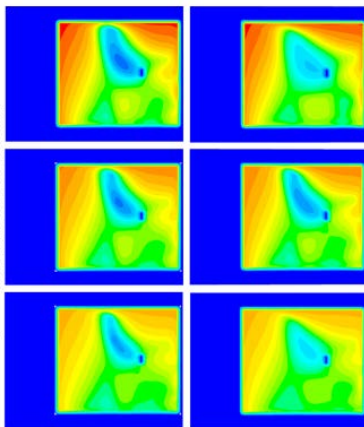

Condensation rate

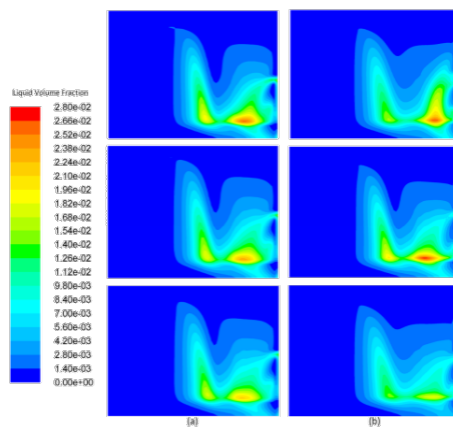

Volume fraction

• Flow control of cavitation Venturi tube

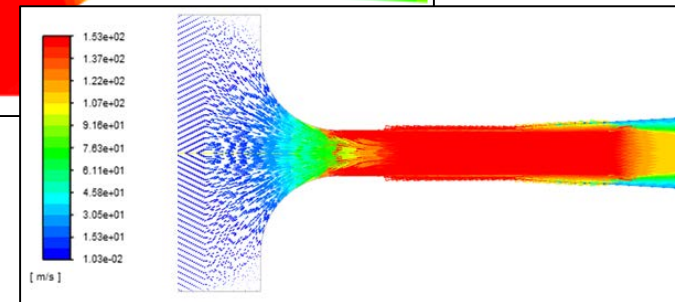
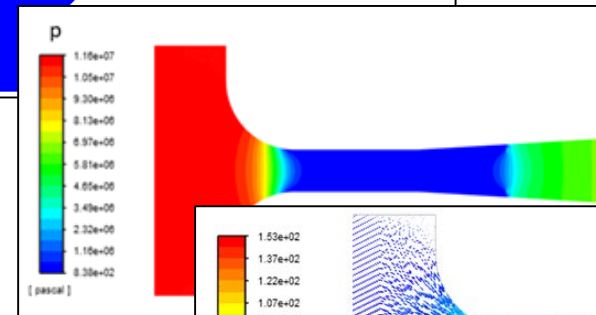
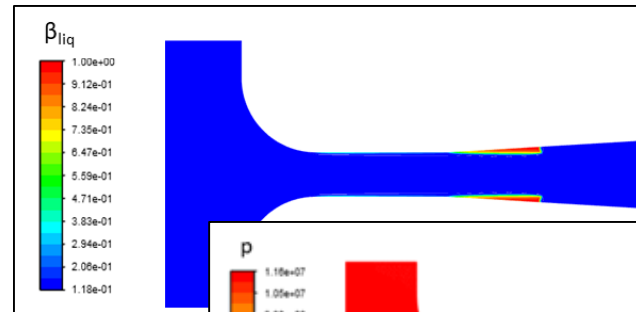
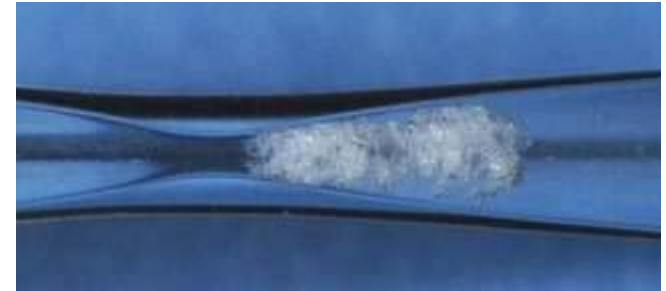

Condensation

• Fundamental study of condensation

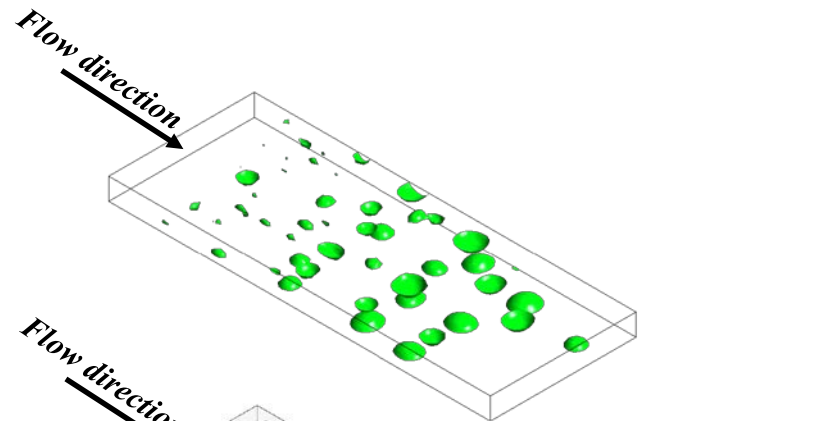

<Convention channel >

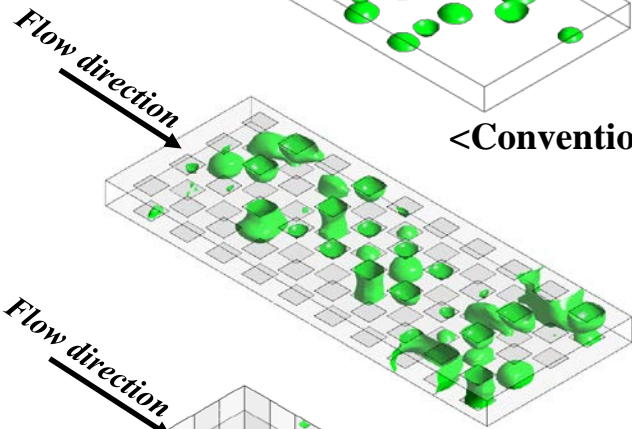

<Dot-patterned channel >

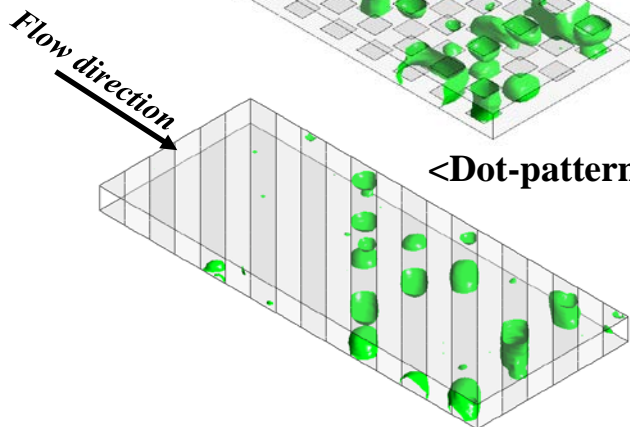

<Diagonal-patterned channel >

• Unit cell analysis for a commercial heat exchanger

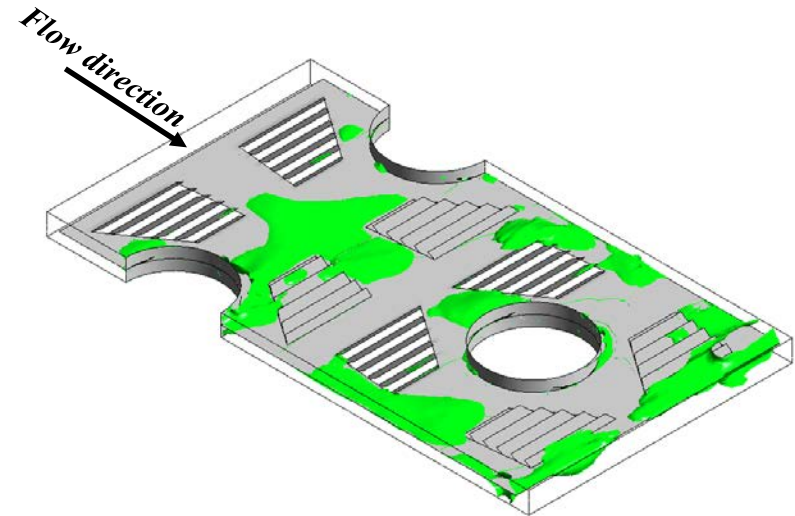

<Louver fin >

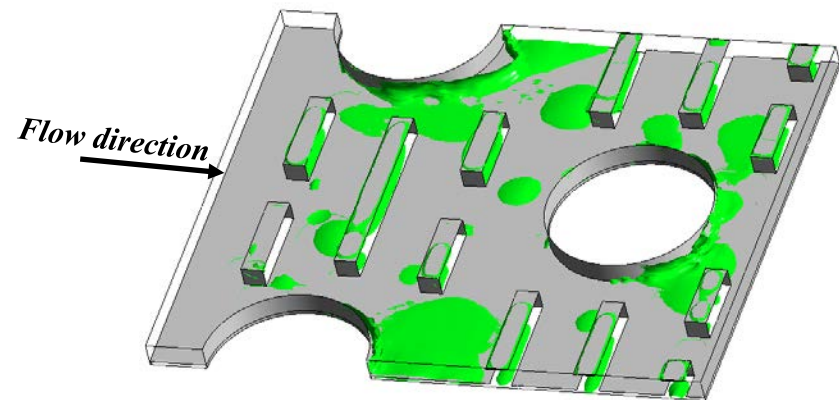

<Slit fin >

Condensation film flow with DNS

- Spectral Element Method (Nek5000)

- Combined DNS + Film flow solver development through global research collaboration.



부산대학교
PUSAN NATIONAL UNIVERSITY

UF UNIVERSITY of
FLORIDA

Nek5000



Argonne
NATIONAL
LABORATORY

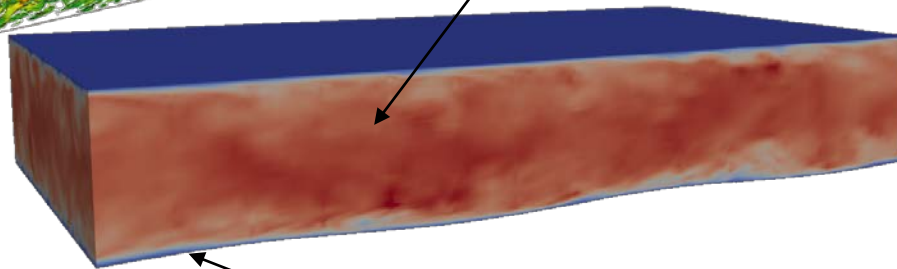
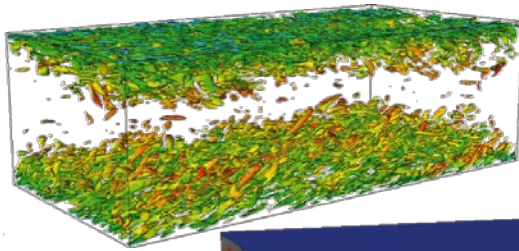

New code development for film flow analysis

Flow direction

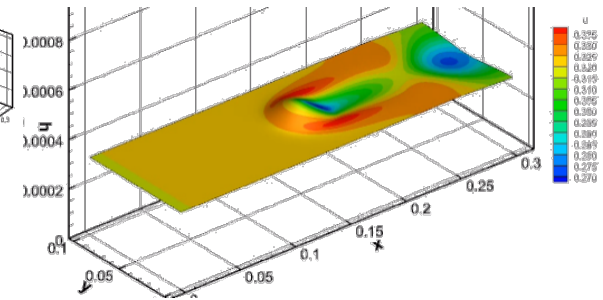
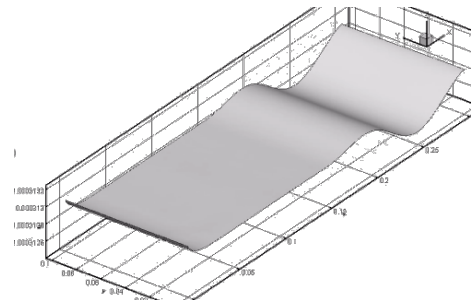
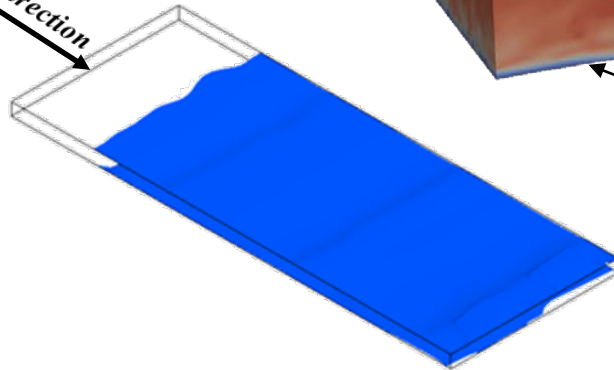

Experiences in industry

• PU foam-filling process for refrigerator

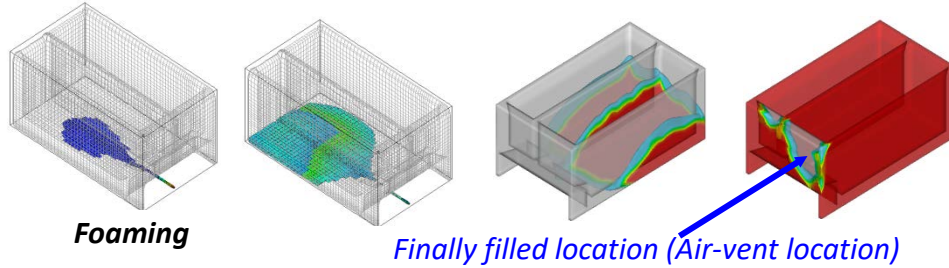

• Frosting in an evaporator

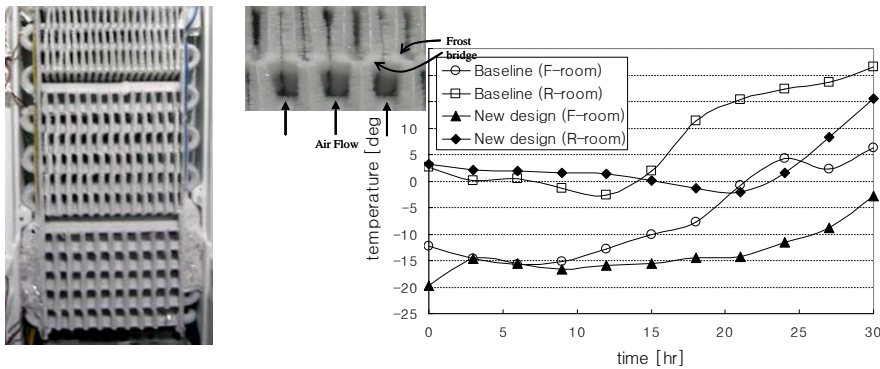

• Solidification(freezing)

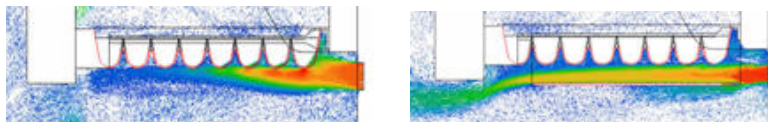

• Even cooling

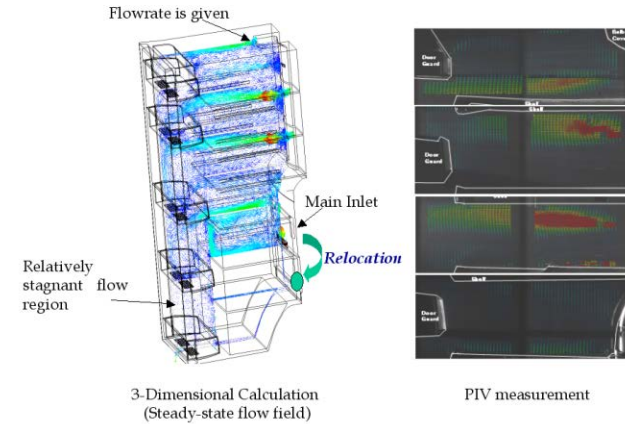

• Fluid machinery

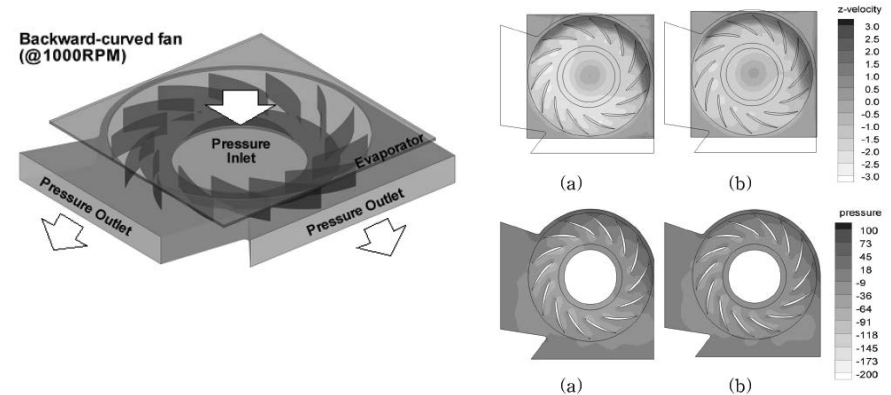

- Thermal management technology
- Advanced numerical model for aero-thermal system
- CFD for multi-phase flow
- **Research programs**

Research programs



Rolls-Royce®

Technology Centre in Thermal Management



University Future
Research Center
in Thermal Design

KETEP

Technology Development of Gas Turbine Blade Reengineering
Specialized for Domestic Operating Environment



National Research
Foundation of Korea

Development of a non-iterative thermal-fluidic topology
optimization technique based on the machine learning



The UAV Gas Turbine Research Center

RIST

재단
법인
포항산업과학연구원
Research Institute of Industrial Science & Technology

Development of Analysis Techniques for the
Thermal-Management of Na-NiCl₂ Battery ESS

DSME

Research of phase change transient analysis for
the heat transfer performance and temperature
distribution in BAHE





Publications in 3 years (SCI-E)



- [01] J.S. Yang, C. Yang, K. Jung and **J.K. Min***, "Numerical studies of natural convection phenomena for a vertical cylinder with multiple lateral baffles in triangular and hexagonal enclosures," *Case Studies in Thermal Engineering*, 45, 102971, 2023.
- [02] F.K. Kholi, S. Park, J.S. Yang and **J.K. Min***, "A detailed review of pulsating heat pipe correlations and recent advances using Artificial Neural Network for improved performance prediction," *International Journal of Heat and Mass Transfer*, 207, 124010, 2023.
- [03] J. Park, M.Y. Ha and **J.K. Min***, "A numerical study on the effect of varying viscosity on the heat transfer inside pipes under low temperature conditions," *Journal of Mechanical Science and Technology*, 36, pp.1315-1328, 2022.
- [04] J.S. Yang, C. Yang, K. Jung and **J.K. Min***, "Numerical study of natural convection heat transfer of vertical cylinder with multiple lateral baffles in square enclosure for sodium beta-alumina batteries," *International Communications in Heat and Mass Transfer*, 134, 106037, 2022.
- [05] H.J. Son, J.S. Yang, J. Park, M.Y. Ha and **J.K.Min***, "A numerical study on the condensation heat transfer in a vertical channel with various wettability conditions and gap spacing," *Case Studies in Thermal Engineering*, 36, 102200, 2022.
- [06] F.K. Kholi, H. Kallath, A. Mucci, M.Y. Ha, J. Chatwynd-Chatwin, and **J.K. Min***, "Experimental study of effects of wicks and boundary conditions on thermal performance of heat pipes," *Journal of Mechanical Science and Technology*, 36(1), pp. 417-432, 2022.
- [07] F.K. Kholi, H. Kallath, A. Mucci, M.Y. Ha, J. Chatwynd-Chatwin, and **J.K. Min***, "Experimental study of the effect of geometrical length to diameter ratios and heater orientations on sintered-based heat pipes thermal behavior," *International Communications in Heat and Mass Transfer*, 129, 105734, 2021.
- [08] F.K. Kholi, J. Park, K. Lee, M.Y. Ha, M. Klingsporn, J. Chatwynd-Chatwin, S.Y. Yoon*, and **J.K. Min***, "Experimental and numerical analysis of the transient behavior of the oil de-congealing process in an aero fuel-cooled oil cooler under low-temperature conditions," *Journal of Engineering for Gas Turbines and Power-Transactions of the ASME*, 143, 091027-1 - 091027-17, 2021.
- [09] J.S. Lee, M.Y. Ha, and **J.K. Min***, "Numerical study on the mixed convection around inclined-pin fins on a heated plate in vertical channels with various bypass ratios," *Case Studies in Thermal Engineering*, 27, 101310-1 - 101310-16, 2021.
- [10] F.K. Kholi, H. Kallath, A. Mucci, M.Y. Ha, J. Chatwynd-Chatwin, and **J.K. Min***, "Experimental investigation of the effects of inclinations and wicks on the thermal behavior of heat pipes for improved thermal applications," *Case Studies in Thermal Engineering*, 26, 100997-1 - 100997-15, 2021.
- [11] J.S. Lee, M.Y. Ha, and **J.K. Min***, "A topology optimization based design of a liquid-cooled heat sink with cylindrical pin fins having varying pitch," *International Journal of Heat and Mass Transfer*, 172,121172-1 - 121172-18, 2021.
- [12] H.J. Hwang, J. Park, and **J.K. Min***, "A numerical study on the flow control characteristics of a cavitating venturi with one- and two-stage diffusers," *Journal of Mechanical Science and Technology*, 35(4), pp. 1463-1472, 2021.
- [13] H. Kallath, F.K. Kholi, Q. Jin, M.Y. Ha, S.H. Park, H. Kim, J. Chatwynd-Chatwin, and **J.K. Min***, "Numerical study of the flow uniformity inside the high-pressure side manifolds of a cooled cooling air heat exchanger," *Applied Thermal Engineering*, 189, pp. 116645-1-116645-14, 2021.
- [14] H. Kallath, F.K. Kholi, M.Y. Ha, and **J.K. Min***, "A Multi-Objective Airfoil Shape Optimization Study using Mesh Morphing and Response Surface Method," *Journal of Mechanical Science and Technology*, 35(3), pp. 1075-1086, 2021.
- [15] A. Mucci, F.K. Kholi, J. Chatwynd-Chatwin, M.Y. Ha, and **J.K. Min***, "Numerical investigation of flow instability and heat transfer characteristics inside pulsating heat pipes with different numbers of turns," *International Journal of Heat and Mass Transfer*, 169,120934-1 - 120934-18, 2021.
- [16] J. Park, M.Y. Ha*, M. Klingsporn, J. Chatwynd-Chatwin, and **J.K. Min***, "An improved numerical analysis of the transient oil de-congealing process in a heat exchanger under low temperature conditions," *Journal of Mechanical Science and Technology*, 35(1), pp. 391-406, 2021.

Further thoughts





- Advanced numerical modeling for thermal management tech for **extreme operating condition**
- **Keywords**
 - HPHT, Cryogenic, Transient
 - Highly efficient system
 - Ultra compactness (novel shape)
 - Safety + Life, reliability, durability
 - Market pressure : Better, Cheaper, Faster
- **Potential of CFD**
 - The use of CFD is wide-spreading across all fields (engineering, environment, medicine, sports etc.).
 - The market for commercial CFD-software has been steadily growing – 13-15 % per year.
 - More potential users are educated in CFD.
 - Computing power is increasing –DNS and LES are becoming possible for more complex flows.
 - High-fidelity simulations (10-100 billions of grid points, or more) will provide better data.
 - Full-scale, full-system analysis will become common.
- **Strategy: New definition of “Multi-”**
 - **Multi-physics**: structural, reliability, life, material, chemical etc.
 - Ready for the high-performance computing as well as the **Multi-fidelity** approach.
 - Intelligent **Multi-objective** design with strong background of fundamental design theory.
 - **Multi-phase** CFD: still long way to go.





Members

	Jae Sung Yang, (Ph.D. candidate) Research: Topology optimization for aero-thermal application OpenFOAM / Nek5000 code development Battery thermal management
	Jung Tae Kim, (Ph.D. candidate) Research: Optimization of fluid machinery
	Seongho Park (Master's student) Research: Optimization of fluid machinery
	Mingyu Kang (Master's student) Research: Heat exchanger analysis

	Megha Paul (Master's student) Research: Condensation
	Jin Hyung Park (Master's student) Research: Gas turbine casing cooling
	Mehdi Tavakoli (Master's student) Research: Condenser analysis in water purifier

Alumni

	Hariharan Kallath, Ph.D.
	Collins Aerospace (Ireland)
	Foster Kwame Kholi, Ph.D.
	Honeywell Aerospace (UK)
	Alberto Mucci, Ph.D.
	Whittle laboratory, University of Cambridge (United Kingdom)
	Junseok Lee, Ph.D.
	Agency for Defense Development (Korea)

	Minbo Shim, Master
	Korea Research Institute for defense Technology (Korea)
	Yeong Woong Oh, Master
	Hyoseong electric co. LTD (Korea)
	Hyo Jae Son, Master
	LG electronics (Korea)
	Namgyoung Lee, Master
	Hyundai Motors (Korea)

Alumni

	Jeonghoon Heo, Master
	Collins Aerospace (Ireland) Myoung Hun Han (Master's student) Research: Condensation Gas turbine casing cooling

Thank you!